

TEKTRONIX®

**SC 501
OSCILLOSCOPE**

INSTRUCTION MANUAL

Tektronix, Inc.
P.O. Box 500
Beaverton, Oregon 97005

Serial Number _____



WARRANTY

All TEKTRONIX instruments are warranted against defective materials and workmanship for one year. Any questions with respect to the warranty should be taken up with your TEKTRONIX Field Engineer or representative.

All requests for repairs and replacement parts should be directed to the TEKTRONIX Field Office or representative in your area. This will assure you the fastest possible service. Please include the instrument Type Number or Part Number and Serial Number with all requests for parts or service.

Specifications and price change privileges reserved.

Copyright © 1974 by Tektronix, Inc., Beaverton, Oregon. Printed in the United States of America. All rights reserved. Contents of this publication may not be reproduced in any form without permission of Tektronix, Inc.

U.S.A. and foreign TEKTRONIX products covered by U.S. and foreign patents and/or patents pending.

TEKTRONIX is a registered trademark of Tektronix, Inc.

TABLE OF CONTENTS

	Page
SECTION 1	
OPERATING INSTRUCTIONS	
Introduction	
Description	1-1
Installation and Removal	1-1
Controls & Connectors	1-2
Operating Considerations	1-3
Deflection Factors	1-3
Applying Signals	1-3
Input Coupling	1-3
Sweep Triggering	1-3
Rear Interface	1-4
Table 1-1 Rear Connector Pin Assignments	1-4
Input Assignments	1-4
Output Assignments	1-5
Electrical Characteristics	1-5
Table 1-2 Vertical Deflection System	1-5
Table 1-3 Horizontal Deflection System	1-6
Table 1-4 Triggering	1-6
Table 1-5 Display	1-7
Table 1-6 Environmental	1-7
SECTION 2	
SERVICING INFORMATION	
Introduction	2-1
Contents	2-1
Maintenance	2-1
Cathode-Ray Tube Replacement	2-1
Test Equipment Required	2-2
Diagrams and Parts Lists	2-3
Electrical Parts List	2-4
Calibration Adjustments	
Component Locations (reverse side of foldout)	
Block Diagram	
Input & Vertical Amplifier (Circuit Description)	
Sweep & Horizontal Amplifier (Circuit Description)	
Z-Axis & CRT Circuit (Circuit Description)	
Low Voltage Supplies (Circuit Description)	
Mechanical Parts List	
Fig. 1 Exploded View	
Fig. 2 Accessories & Repackaging	
CHANGE INFORMATION	

SC 501 OSCILLOSCOPE

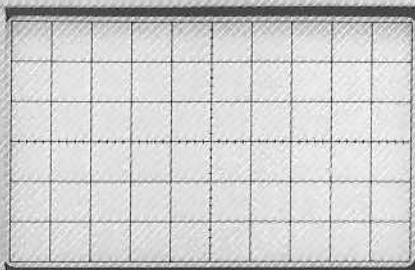

FOCUS

INTENSITY

VERT INPUT



1M 47pF

POWER



VARIABLE



X10

OUT:DC



AC COUPL

BOTH OUT: 10mV/DIV

100 mV



1 V

POS



INT EXT



LEVEL/SLOPE

- 0 +



PULL XS

TRIGGER

VARIABLE



X10 PULL XS

OUT: BOTH OUT: X1

ms



X10

POS



EXT HORIZ



EXT TRIG



TEKTRONIX®



OPERATING INSTRUCTIONS

INTRODUCTION

DESCRIPTION

The SC 501 general purpose oscilloscope is designed to operate in a TM 500 Series Power Module. The SC 501 has a bandwidth of at least 5 MHz and a calibrated vertical deflection range from 10 mV/DIV to 1 V/DIV, selectable in decade steps. An uncalibrated VARIABLE control extends this range to at least 10 volts/division.

Calibrated sweep rates are selected by pushbutton-controlled logic in decade steps from 1 ms/DIV to 100 ms/DIV (millisecond range) and in decade steps from 1 μ s/DIV to 100 μ s/DIV (microsecond range). A VARIABLE control extends the slowest calibrated sweep rate to at least 1 second/division and a X5 Magnifier extends the fastest calibrated sweep rate to at least 200 nanoseconds/division.

The triggering circuits allow stable triggering from either internal or external sources. An AUTO triggering mode and manual LEVEL/SLOPE selection is combined in a single control. With no input signal, automatic triggering provides a bright baseline at all sweep rates.

An internal switch converts the horizontal deflection system of the SC 501 to an External Horizontal Amplifier mode of operation.

INSTALLATION AND REMOVAL

The SC 501 is calibrated and ready for use as received. Referring to Fig. 1-1, install the SC 501 and turn on the Power Module. Check that the POWER indicator on the SC 501 front panel comes on.

NOTE

It is recommended that the Power Module be turned off before inserting or removing the SC 501. Arcing at the rear connector terminals can reduce connector life. However, no internal damage will result if the SC 501 is inserted in a live Power Module.

Refer to CONTROLS & CONNECTORS (Fig. 1-2) for description of front panel controls, connectors and indicators.

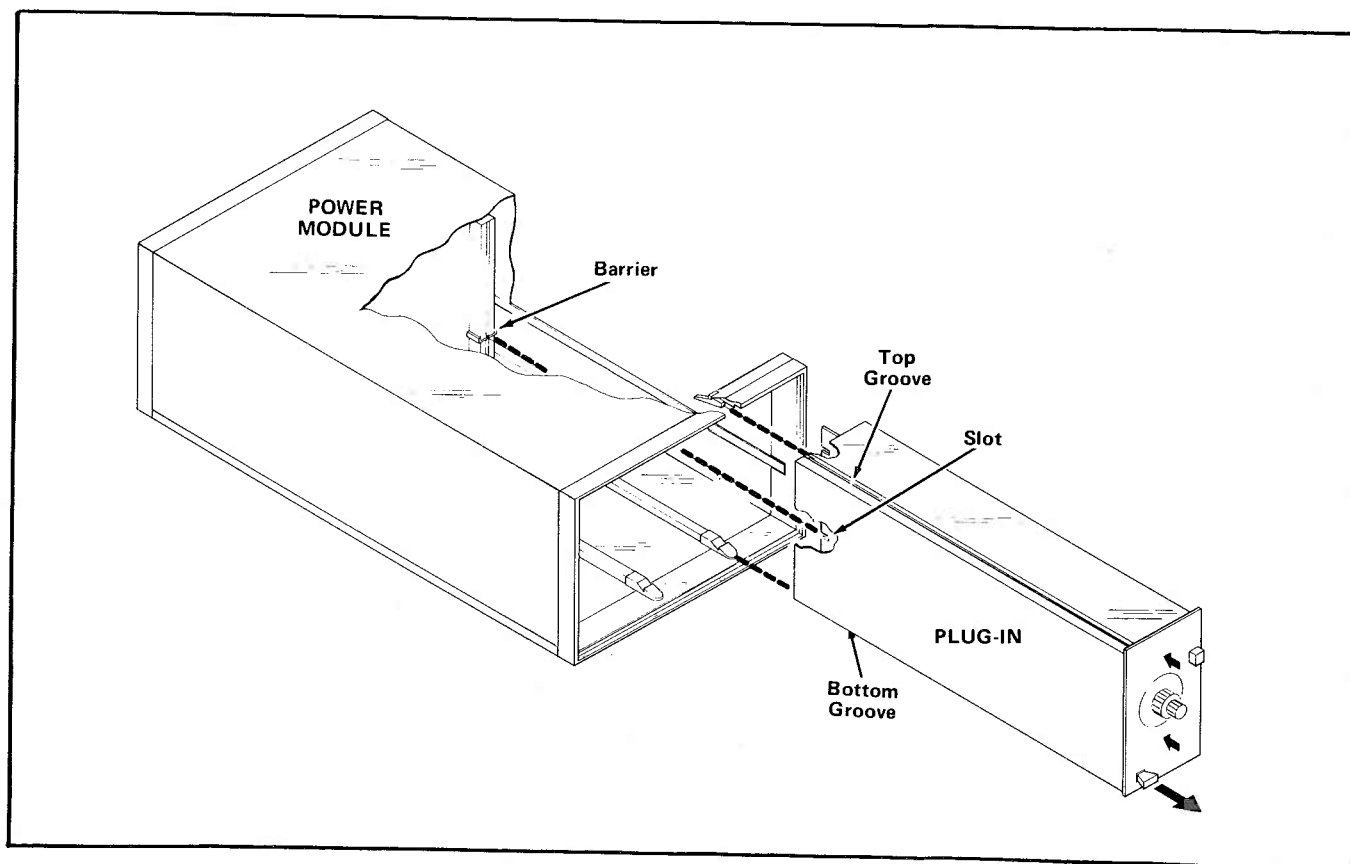

Fig. 1-1. Plug-In Installation and removal.

CONTROLS & CONNECTORS

NOTE

Switch for Y-T or X-Y operation located internally; right side, lower center of instrument.

Vertical Input Connector. BNC connector for vertical amplifier signal input.

VARIABLE Control
Extends each calibrated vertical deflection factor over a 10:1 range. Maximum at least 10 V/Div.

Trigger Controls.
LEVEL/SLOPE selection from INT or EXT sources. Pull LEVEL/SLOPE control out for AUTO triggering mode.

Sweep VARIABLE and X5 Mag.
Variable controls extends each calibrated sweep rate over a 10:1 range. Slowest sweep rate 1 sec/Div. Pull variable out for X5 magnification of each calibrated sweep rate. Fastest calibrated sweep rate at least 200 ns/Div.

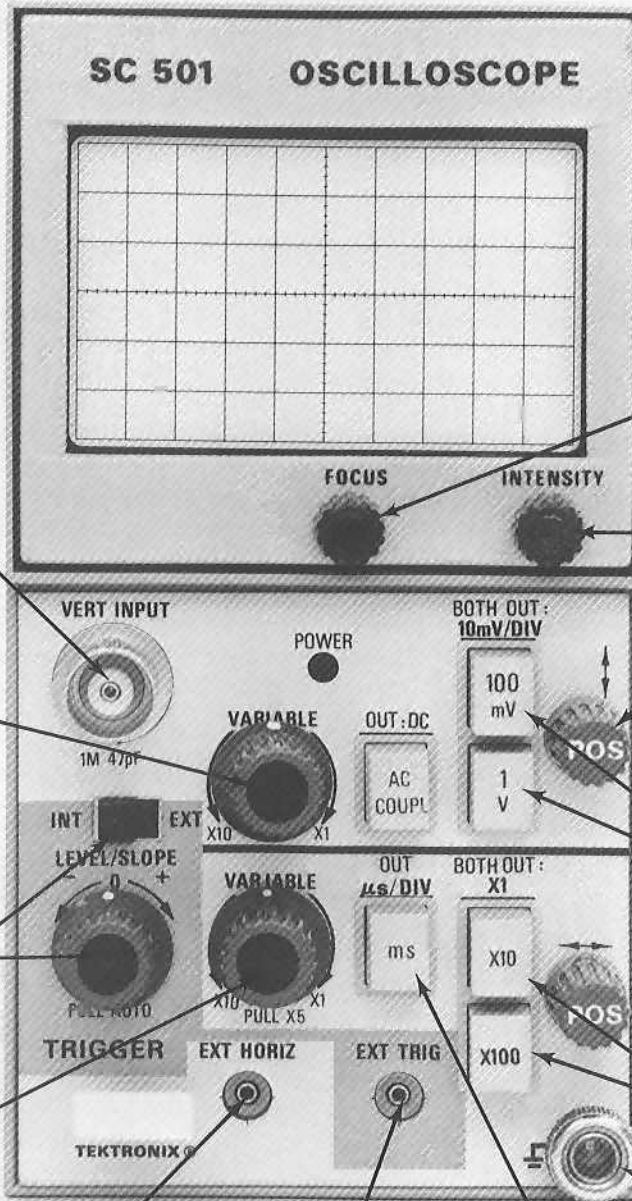

FOCUS Control
Provides adjustment to obtain a well-defined display.

INTENSITY Control.
Controls display brightness.

POSITION Control.
Positions display vertically.

Volts/Div Pushbuttons.
Two self-canceling switches select the calibrated deflection factors as indicated. To return to the 10 mV/Div setting, depress the unused pushbutton just enough to release the other pushbutton.

POSITION Control.
Positions display horizontally.

Time/Div Pushbuttons.
Two self-canceling switches select the calibrated sweep rates as indicated.

Ground Connector.
Chassis return connector for signals.

EXT HORIZ pin jack.

Operates in conjunction with internal switch to allow X-Y operation.

EXT TRIG pin jack.
Allows sweep triggering from external sources.

Time/Div Range Pushbutton.

A push-push switch to allow selection of a millisecond or microsecond range for the calibrated Time/Div settings.

Fig. 1-2. CONTROLS & CONNECTORS.

OPERATING CONSIDERATIONS

DEFLECTION FACTORS

The amount of vertical deflection produced by a signal is determined by the signal amplitude, the attenuation factor (if any) of the probe, the setting of the Volts/Div pushbuttons, and the setting of the associated VARIABLE control.

Use the largest deflection factor (1 V/DIV) when first connecting the SC 501 to an unknown voltage source. If the deflection is too small to make the measurement, switch to a lower deflection factor.

The deflection factors indicated by the Volts/Div pushbuttons are calibrated only when the VARIABLE control is rotated fully clockwise.

The range of the VARIABLE control is at least 10:1. It provides uncalibrated deflection factors covering the full range between the fixed settings of Volts/Div pushbuttons. The VARIABLE control extends the maximum deflection factor to at least 10 volts/division.

APPLYING SIGNALS

While most connections to the SC 501 will probably be made using coaxial cables, probes offer another convenient method of applying a signal to the input of the SC 501. Tektronix probes are shielded to prevent pickup of electrostatic interference. A 10X attenuator probe offers a high input impedance and allows the circuit under test to perform very close to normal operating conditions. The SC 501 is compatible with probes such as Tektronix P6006 and P6028 Passive Probes. When probe attenuation is not desired, a Tektronix P6011 Passive Probe is recommended.

NOTE

Probe compensation should be checked with a known signal (risetime of 100 nanoseconds or less) before using the SC 501. Input time constant is normalized for each attenuator step.

Unshielded test leads can sometimes be used to connect a signal source to the SC 501, particularly when a high-level, low-frequency signal is monitored at a low impedance point. However, when any of these factors are missing, it becomes increasingly important to use shielded cables. In all cases, the signal transporting leads should be kept as short as practical. Be certain that a common ground connection is established between the device under test and the SC 501. The shield of a coaxial cable or ground strap of a signal probe provides an adequate common ground connection.

INPUT COUPLING

The AC COUPL pushbutton switch allows a choice of input coupling. The type of display desired determines the method of coupling used.

Dc coupling (button out) can be used for most applications. However, if the dc component of the applied signal is much larger than the ac component, ac coupling (button in) will probably provide a better display. Dc coupling should be used to display an ac signal below about 3 hertz.

In the ac coupling position, the dc component is blocked by a series capacitor in the input circuit. The low-frequency response in the ac position is about 3 hertz (−3 dB point); therefore, some low-frequency attenuation and phase shift can be expected near this frequency limit. Distortion will also appear in square waves that have low-frequency components.

SWEEP TRIGGERING

When the source switch is in the INT position, the sweep is triggered by a sample of the signal applied to the VERT INPUT connector. The display is stable for either Normal or AUTO triggering modes as long as the signal frequency is above 10 Hz. Below 10 Hz, it may be desirable to use Normal mode triggering (LEVEL/SLOPE control pushed in). The AUTO triggering mode (LEVEL/SLOPE control pulled out) reduces operator adjustments and provides a bright baseline in the absence of an input signal.

When the source switch is in the EXT position, the sweep is triggered by the signal applied to the EXT TRIG pin jack. The signal applied to the EXT TRIG pin jack must be time-related to the signal applied to the VERT INPUT connector in order to prevent drift in the display.

REAR INTERFACE

TABLE 1-1

REAR CONNECTOR PIN ASSIGNMENTS (REAR VIEW)

Pin No.	Left (B)	Right (A)
28	Unassigned	Unassigned
27	¹ + Gate Out	¹ EXT TRIG signal
26	Unassigned	¹ EXT TRIG common
23-25	Unassigned	Unassigned
22	Unassigned	Unassigned
18-21	Unassigned	Unassigned
17	¹ VERT INPUT signal	¹ EXT HORIZ common
16	¹ VERT INPUT common	¹ EXT HORIZ signal
14	Unassigned	Unassigned
15	Unassigned	Ramp Out
13	Not used	Not used
12	+33.5 V Filtered dc	+33.5 V Filtered dc
11	Collector PNP Series-Pass Transistor	Base PNP Series-Pass Transistor
10	Not used	Emitter PNP Series-Pass Transistor
9	±33.5 Vdc common	±33.5 Vdc common
8	-33.5 V Filtered dc	-33.5 V Filtered dc
7	Collector NPN Series-Pass Transistor	Emitter NPN Series-Pass Transistor
6	No Connection	Base NPN Series-Pass Transistor
1-5	Not used	Not used

¹ Instrument not supplied with these connections. See INPUT and OUTPUT ASSIGNMENT.

NOTE

Refer to Power Module instruction manual for information concerning pins labeled Not used.

INPUT ASSIGNMENTS

The VERT INPUT signal, EXT TRIG signal and EXT HORIZ signal can be applied through the rear interface connectors if the SC 501 is modified as follows:

A. VERT INPUT signal.

1. Unsolder the 200 ohm resistor attached to the VERT INPUT connector. Connect the center conductor of a coaxial cable to the 200 ohm resistor. Connect the coaxial cable shield to ground.

2. Connect the other end of the coaxial cable: center conductor to pin 17B and shield to pin 16B (common).

NOTE

Parallel operation may be obtained if another 200 ohm resistor is connected in series with the center conductor of a coaxial cable to the junction of R100 and the main circuit board. The addition of any coaxial cable to input circuits affects the input impedance.

B. EXT TRIG signal.

1. Connect the center conductor of a coaxial cable to the EXT TRIG pin jack. Ground the coaxial cable shield.

2. Connect the other end of the coaxial cable: center conductor to pin 27A and shield to pin 26A (common).

3. Set the trigger source switch to the EXT position to trigger the sweep from pin 27A.

C. EXT HORIZ signal.

1. Connect the center conductor of a coaxial cable to the EXT HORIZ pin jack. Ground the coaxial cable shield.

2. Connect the other end of the coaxial cable: center conductor to pin 16A and shield to pin 17A (common).

OUTPUT ASSIGNMENTS

A + Gate Out signal can be routed to the rear interface connector via the center conductor of a coaxial cable to pin 27B. Shield ground may be any convenient location. A Ramp Out Signal is factory wired to pin 15A. Other pins (unassigned) are available at the rear interface connector for routing signals to and from the SC 501 for specialized applications. One or more compartments of a multi-plug-in Power Module can be wired with barriers installed to provide specific functions between compartments. See Power Module instruction manual for additional information.

ELECTRICAL CHARACTERISTICS

PERFORMANCE CONDITIONS

The electrical characteristics are valid only if the SC 501 has been calibrated at an ambient temperature between

+20°C and +30°C and is operating at an ambient temperature between 0°C and +50°C unless otherwise noted.

**TABLE 1-2
VERTICAL DEFLECTION SYSTEM CHARACTERISTICS**

Characteristics	Performance Requirements	Supplemental Information
Bandwidth	Dc to at least 5 MHz.	
Deflection Factors	10 mV/div, 100 mV/div, and 1 V/div.	
Accuracy	Within 3% of indicated deflection.	VARIABLE in X1 (fully cw) position: gain correctly set at 10 mV/div.
Uncalibrated (Variable) Range	Continuously variable between steps. Extends deflection factor to a maximum of 10 V/div.	10:1 range for all attenuator settings.
Low Frequency Linearity		0.1 division or less compression or expansion of a two division (at center screen) signal when positioned to the top and bottom of the graticule area.
Input Coupling	Ac or dc.	Lower bandwidth limit when ac-coupled is approximately 3 Hz.
Input Impedance	1 MΩ paralleled by 47 pF.	Input time constant is normalized for each attenuator step.
Maximum Safe Input Voltage	350 V (dc + peak ac).	

**TABLE 1-3
HORIZONTAL DEFLECTION SYSTEM CHARACTERISTICS**

Characteristics	Performance Requirements	Supplemental Information
Time Base		
Calibrated Sweep Rates	1 ms/div, 10 ms/div, 100 ms/div, 1 μ s/div, 10 μ s/div, 100 μ s/div.	
Uncalibrated (Variable) Range	Extends slowest calibrated rate to at least 1 sec/div.	10:1 range for all calibrated rates. Zero to 10 V ramp output available at rear interface connector for all sweep rates (excluding X5 magnification).
X5 Magnifier (fixed)	Extends fastest calibrated sweep rate to at least 200 ns/div.	
Accuracy (Over 8 div)	Within 5% for all sweep rates.	Disregard first 0.5 μ s of total sweep length.
Linearity (any two division portion within center eight divisions)	Within 5%.	Disregard first 0.5 μ s of total sweep length.
External Horizontal Amplifier		Internal switch must be set to X-Y position.
Bandwidth	Dc to 100 kHz.	Internally calibrated for 100 mV/div.
Input Impedance	Approximately 100 k Ω paralleled by 25 pF.	
Maximum Input Voltage	± 3 V.	

**TABLE 1-4
TRIGGERING CHARACTERISTICS**

Characteristics	Performance Requirements	Supplemental Information
Normal Trigger Sensitivity (Trigger LEVEL/SLOPE control pushed in)		
Internal: Dc-coupled	0.4 major division of deflection at dc increasing to 1.0 major division of deflection at 5 MHz.	
External: Dc-coupled	1 V minimum to 5 V maximum from dc to 5 MHz.	
Input Impedance	22 K Ω paralleled by approximately 150 pF.	
AUTO triggering (Trigger LEVEL/SLOPE control pulled to out position)	Sweep free-runs in absence of trigger signal or for trigger repetition rates below 10 Hz.	

TABLE 1-5
DISPLAY CHARACTERISTICS

Characteristics	Performance Requirements	Supplemental Information
Graticule Type Area	Internal black line, nonilluminated. Six divisions vertical by 10 divisions horizontal. Each division equals 0.203 inch.	
Phosphor	P31 standard.	

TABLE 1-6
ENVIRONMENTAL CHARACTERISTICS

Characteristics	Performance Requirements	Supplemental Information
Temperature Operating Storage	0°C to +50°C. -40°C to +75°C.	
Altitude Operating Storage	To 15,000 feet. To 50,000 feet.	
Vibration Operating and Non-operating	With the instrument complete and operating, vibration frequency swept from 10 to 50 to 10 Hz at 1 minute per sweep. Vibrate 15 minutes in each of the three major axes at 0.015 inch total displacement. Hold 3 minutes at any major resonance, or in none, at 50 Hz. Total time, 54 minutes.	
Shock Operating and Non-operating	30 g's, 1/2 sine, 11 ms duration, 2 shocks in each direction along 3 major axes, for a total of 12 shocks.	

SERVICING INFORMATION

INTRODUCTION

CONTENTS

This section of the manual contains information necessary to service the SC 501.

A block diagram and schematic drawings are provided as an aid in understanding the theory of operation of the SC 501. A circuit description for each schematic drawing is included on the associated foldout page.

Adjustment and calibration procedures are provided on a foldout page with supporting illustrations that show internal adjustment locations and measurement check points.

Also included is the electrical parts list and a component location grid to facilitate the location of the components on the etched circuit boards.

Mechanical parts are listed in the rear of this section with an exploded view of the instrument. A list of standard

accessories and a carton assembly drawing are on the back of the exploded view foldout page.

MAINTENANCE

General system maintenance procedures are provided in the Power Module instruction manual, i.e., preventive maintenance, troubleshooting aids, parts removal and replacement procedures, parts ordering information, etc.

Adjustment of the SC 501 may be required after a repair has been made, or after long time intervals in which normal aging of components may affect instrument accuracy.

Before complete calibration, thoroughly clean and inspect this instrument as outlined in the service section of the Power Module instruction manual.

Refer to Fig. 2-1 as an aid in removing or replacing the cathode-ray tube.

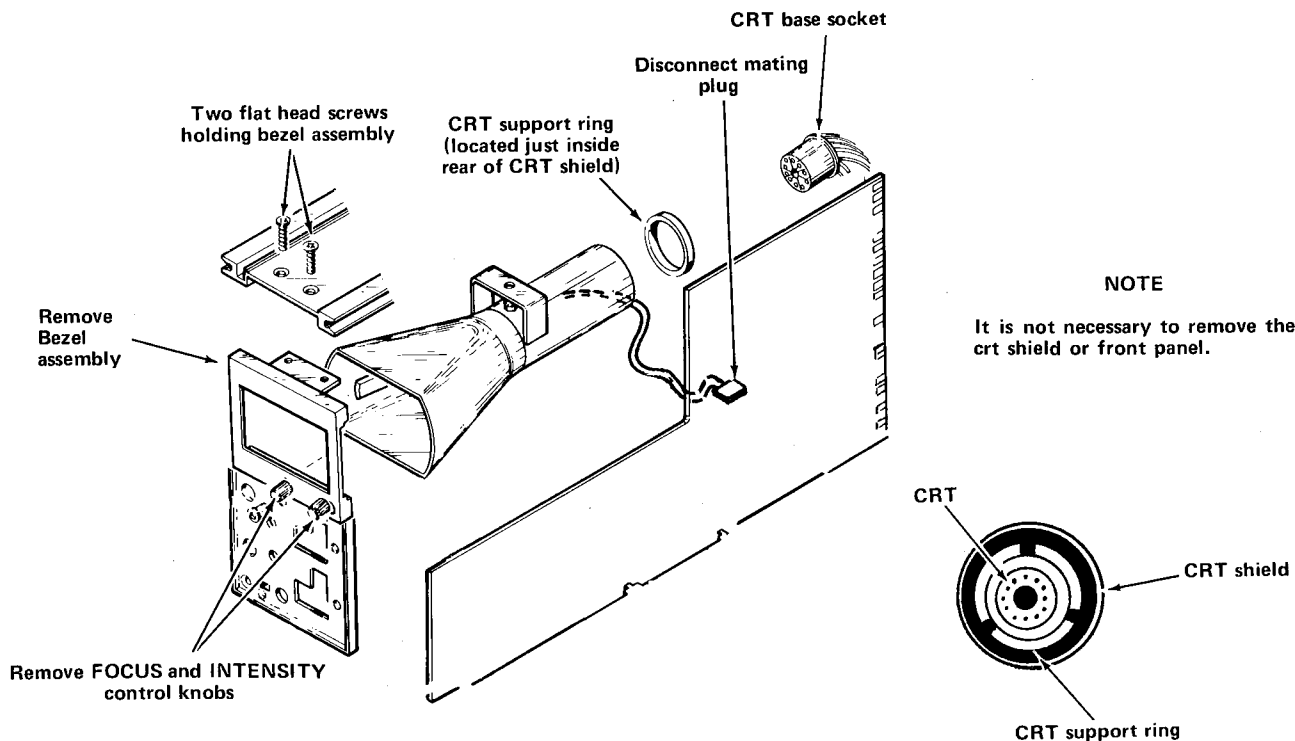

WARNING

Use care when handling a crt. Protective clothing and safety glasses should be worn. Avoid striking it on any object which might cause it to crack or implode. When storing a crt, place it in a protective carton or set it face down in a protected location on a smooth surface with a soft mat under the faceplate to protect it from scratches.

Fig. 2-1. Replacing the cathode-ray tube. Replacing the crt will require partial instrument readjustments. Refer to CALIBRATION ADJUSTMENTS foldout page.

TEST EQUIPMENT REQUIRED

The following test equipment and accessories, or its equivalent, is required for complete calibration of the SC 501. Specifications given for the test equipment are the minimum necessary for accurate calibration or measurement. All test equipment is assumed to be correctly calibrated and operating with specifications.

If other test equipment is substituted, control settings or calibration setup may need to be altered to meet the requirements of the equipment used. Detailed operating instructions for the test equipment used are not given in the adjustment or calibration procedures. Refer to the instruction manual for the test equipment if more information is desired.

1. TM 500 Series Power Module
2. Plug-in Extender. Tektronix Part No. 067-0645-01.
3. Variable Autotransformer. Must be capable of supplying sufficient wattage over a range of 90 to 132 V or 180 to 264 V. Autotransformer must have an ac voltmeter to indicate output voltage.
4. Dc Voltmeter: accuracy within 0.1% and a measurement range from -1000 V to $+100$ V. For example, a DM 501 Digital Multimeter, or any high impedance dc voltmeter meeting the above requirements.
5. Amplitude Calibrator: accuracy within 0.25%. Output amplitudes from 50 mV to 10 V. Square-wave repeti-

tion rate about 1 kHz. For example, Tektronix Calibration Generator PG 506 or Calibration Fixture 067-0502-01.

6. Test Oscilloscope. Minimum bandpass of 1 MHz and deflection factor of at least 10 mV/div with a 10X probe. For example, Tektronix 5103/D10 oscilloscope with 5B10N Time Base/Amplifier, 5A23N Amplifier plug-in and a P6006 probe, or any oscilloscope that meets the above requirements.
7. Leveled Sine-Wave Generator. Tektronix SG 503 or 191 Constant-Amplitude Signal Generator.
8. Time-Mark Generator. Tektronix TG 501 or 2901.
9. Input Normalizer 47 pF (BNC). Tektronix Calibration Fixture 067-0541-00.
10. 50-ohm termination with BNC connectors. Tektronix Part No. 011-0049-01.
11. Coaxial cables. Impedance 50 ohms, RG-58/U, maximum length 42 inches, BNC connectors. Tektronix Part No. 012-0057-01.
12. Adapter, BNC to pin jack. Tektronix Part No. 175-1178-00, or equivalent.
13. Screwdriver, three-inch shaft, 3/32 bit. Xcelite R-3323.
14. Low-capacitance screwdriver, one and one-half inch shaft. Tektronix Part No. 003-0000-00.

DIAGRAMS AND PARTS LISTS

SYMBOLS AND REFERENCE DESIGNATORS

Electrical components shown on the diagrams are in the following units unless noted otherwise:

- Capacitors = Values one or greater are in picofarads (pF)
Values less than one are in microfarads (μ F)
- Resistors = Ohms (Ω)

Symbols used on the diagrams are based on ANSI Y32.2 – 1970.

Logic symbology is based on MIL-STD-806B in terms of positive logic. Logic symbols depict the logic function performed and may differ from the manufacturer's data.

The following special symbols are used on the diagrams:

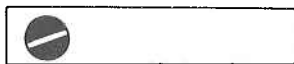

External Screwdriver adjustment.

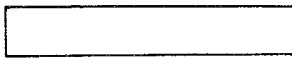

External control or connector.



Clockwise control rotation in direction of arrow.



Refer to diagram number indicated in diamond.



Refer to waveform number indicated in hexagon.

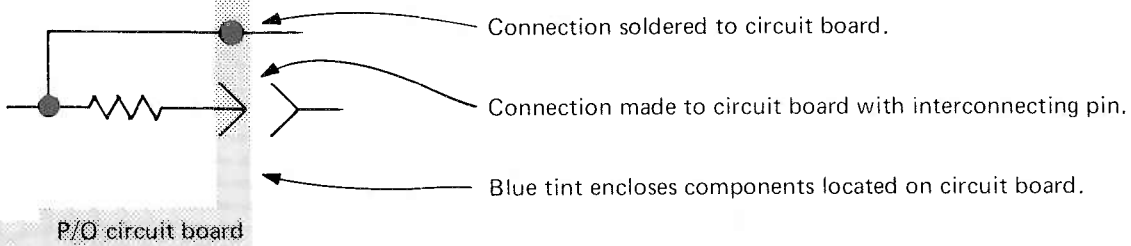

Connection soldered to circuit board.

Connection made to circuit board with interconnecting pin.

Blue tint encloses components located on circuit board.

REPLACEABLE ELECTRICAL PARTS

PARTS ORDERING INFORMATION

Replacement parts are available from or through your local Tektronix, Inc. Field Office or representative.

Changes to Tektronix instruments are sometimes made to accommodate improved components as they become available, and to give you the benefit of the latest circuit improvements developed in our engineering department. It is therefore important, when ordering parts, to include the following information in your order: Part number, instrument type or number, serial number, and modification number if applicable.

If a part you have ordered has been replaced with a new or improved part, your local Tektronix, Inc. Field Office or representative will contact you concerning any change in part number.

Change information, if any, is located at the rear of this manual.

SPECIAL NOTES AND SYMBOLS

X000 Part first added at this serial number
00X Part removed after this serial number

ITEM NAME

In the Parts List, an Item Name is separated from the description by a colon (:). Because of space limitations, an Item Name may sometimes appear as incomplete. For further Item Name identification, the U.S. Federal Cataloging Handbook H6-1 can be utilized where possible.

ABBREVIATIONS

ACTR	ACTUATOR	PLSTC	PLASTIC
ASSY	ASSEMBLY	QTZ	QUARTZ
CAP	CAPACITOR	RECP	RECEPTACLE
CER	CERAMIC	RES	RESISTOR
CKT	CIRCUIT	RF	RADIO FREQUENCY
COMP	COMPOSITION	SEL	SELECTED
CONN	CONNECTOR	SEMICOND	SEMICONDUCTOR
ELCTLT	ELECTROLYTIC	SENS	SENSITIVE
ELEC	ELECTRICAL	VAR	VARIABLE
INCAND	INCANDESCENT	WW	WIREWOUND
LED	LIGHT EMITTING DIODE	XFMR	TRANSFORMER
NONWIR	NON WIREWOUND	XTAL	CRYSTAL

CROSS INDEX MFR. CODE NUMBER TO MANUFACTURER

MFR.CODE	MANUFACTURER	ADDRESS	CITY,STATE,ZIP
00853	Sangamo Electric Co., S. Carolina Div.	P. O. Box 128	Pickens, SC 29671
01121	Allen-Bradley Co.	1201 2nd St. South	Milwaukee, WI 53204
02735	RCA Corp., Solid State Division	Route 202	Somerville, NY 08876
03508	General Electric Co., Semi-Conductor Products Dept.	Electronics Park	Syracuse, NY 13201
04713	Motorola, Inc., Semiconductor Products Div.	5005 E. McDowell Rd.	Phoenix, AZ 85036
07263	Fairchild Semiconductor, A Div. of Fairchild Camera and Instrument Corp.	464 Ellis St.	Mountain View, CA 94042
07910	Teledyne Semiconductor	12515 Chadron Ave.	Hawthorne, CA 90250
10389	Chicago Switch, Inc.	2035 Wabansia Ave.	Chicago, IL 60647
12040	National Semiconductor Corp.	Commerce Drive	Danbury, CT 06810
12697	Clarostat Mfg. Co., Inc.	Lower Washington St.	Dover, NH 03820
14752	Electro Cube Inc.	1710 S. Del Mar Ave.	San Gabriel, CA 91776
22229	Solitron Devices, Inc., Diodes, Integrated Circuits and CMOS	8808 Balboa Ave.	San Diego, CA 92123
24931	Specialty Connector Co., Inc.	3560 Madison Ave.	Indianapolis, IN 46227
27014	National Semi-Conductor Corp.	2900 San Ysidro Way	Santa Clara, CA 95051
34553	Amperex Electronic Corp., Component Div.	35 Hoffman Ave.	Happauge, NY 11787
56289	Sprague Electric Co.	31 South St.	North Adams, MA 01247
63743	Ward Leonard Electric Co., Inc.	5757 N. Green Bay Ave.	Mount Vernon, NY 10550
71590	Centralab Electronics, Div. of Globe-Union, Inc.	4433 Ravenswood Ave.	Milwaukee, WI 53201
71744	Chicago Miniature Lamp Works		Chicago, IL 60640
72136	Electro Motive Corp., Sub of International Electronics Corp.	South Park and John Streets	Willimantic, CT 06226
72982	Erie Technological Products, Inc.	644 W. 12th St.	Erie, PA 16512
73138	Beckman Instruments, Inc., Helipot Div.	2500 Harbor Blvd.	Fullerton, CA 92634
74970	Johnson, E. F., Co.	299 10th Ave. S. W.	Waseca, MN 56093
75042	TRW Electronic Components, IRC Fixed Resistors, Philadelphia Division	401 N. Broad St.	Philadelphia, PA 19108
79727	C-W Industries	550 Davisville Rd.	Warminster, PA 18974
80009	Tektronix, Inc.	P. O. Box 500	Beaverton, OR 97077
91637	Dale Electronics, Inc.	P. O. Box 609	Columbus, NB 68601

Ckt No.	Tektronix Part No.	Serial/Model No.		Name & Description	Mfr Code	Mfr Part Number
		Eff	Dscont			
A1	670-3304-00	B010100	B039999	CKT BOARD ASSY:MAIN	80009	670-3304-00
A1	670-3304-01	B040000		CKT BOARD ASSY:MAIN	80009	670-3304-01
A2	670-3364-00	B010100	B039999	CKT BOARD ASSY:AMPLIFIER	80009	670-3364-00
A2	670-3364-01	B040000		CKT BOARD ASSY:AMPLIFIER	80009	670-3364-01
C100	283-0189-00			CAP.,FXD,CER DI:0.1UF,20%,400V	72982	8151N401X5R104M
C102	281-0184-00			CAP.,VAR,PLSTC:2-18PF,500VDC	34553	2222-809-05003
C104	281-0153-00			CAP.,VAR,AIR DI:1.7-10PF,250V	74970	187-0106-005
C105	281-0628-00			CAP.,FXD,CER DI:15PF,5%,600V	72982	301-000C0G0150G
C107	283-0641-00			CAP.,FXD,MICA D:180PF,1%,100V	00853	D151E181F0
C110	281-0184-00			CAP.,VAR,PLSTC:2-18PF,500VDC	34553	2222-809-05003
C112	281-0153-00			CAP.,VAR,AIR DI:1.7-10PF,250V	74970	187-0106-005
C113	281-0628-00			CAP.,FXD,CER DI:15PF,5%,600V	72982	301-000C0G0150G
C115	283-0696-00			CAP.,FXD,MICA D:2300PF,1%,500V	72136	DM19E232F0500
C117	281-0184-00			CAP.,VAR,PLSTC:2-18PF,500VDC	34553	2222-809-05003
C118	281-0576-00			CAP.,FXD,CER DI:11PF,5%,500V	72982	301-050C0G0110J
C120	283-0003-00			CAP.,FXD,CER DI:0.01UF,+80-20%,150V	72982	855-547E103Z
C124	290-0525-00			CAP.,FXD,ELCTLT:4.7UF,20%,50V	56289	196D475X0050KAL
C127	281-0518-00			CAP.,FXD,CER DI:47PF,+/-9.4PF,500V	72982	301-000U2J0470M
C138	283-0003-00			CAP.,FXD,CER DI:0.01UF,+80-20%,150V	72982	855-547E103Z
C154	281-0528-00			CAP.,FXD,CER DI:82PF,+/-8.2PF,500V	72982	301-000U2M0820K
C156	290-0525-00			CAP.,FXD,ELCTLT:4.7UF,20%,50V	56289	196D475X0050KAL
C169	281-0576-00			CAP.,FXD,CER DI:11PF,5%,500V	72982	301-050C0G0110J
C200	281-0550-00			CAP.,FXD,CER DI:120PF,10%,500V	72982	301-000X5P0121K
C204	281-0629-00			CAP.,FXD,CER DI:33PF,5%,600V	72982	308-000C0G0330G
C205	290-0522-00			CAP.,FXD,ELCTLT:1UF,20%,50V	56289	196D105X0050HAL
C210	283-0004-00			CAP.,FXD,CER DI:0.02UF,+80-20%,150V	72982	855-547E203Z
C218	290-0522-00			CAP.,FXD,ELCTLT:1UF,20%,50V	56289	196D105X0050HAL
C220	283-0051-00			CAP.,FXD,CER DI:0.0033UF,5%,100V	72982	8131N145C0G332J
C228	283-0594-00			CAP.,FXD,MICA D:0.001UF,1%,100V	00853	D151F102F0
C229	285-1049-00			CAP.,FXD,PLSTC:0.01UF,1%,200V	14752	230B1C103F
C230	285-1051-00			CAP.,FXD,PLSTC:1UF,1%,200V	14752	230B1C105F
C270	283-0003-00			CAP.,FXD,CER DI:0.01UF,+80-20%,150V	72982	855-547E103Z
C305	281-0524-00			CAP.,FXD,CER DI:150PF,+/-30PF,500V	72982	301-000X5U0151M
C310	281-0658-00			CAP.,FXD,CER DI:6.2PF,+/-0.25PF,500V	72982	301-000C0H0629C
C318	281-0638-00			CAP.,FXD,CER DI:240PF,5%,500V	72982	301-000Z5D0241J
C339	281-0526-00			CAP.,FXD,CER DI:1.5PF,+/-0.5PF,500V	72982	301-000S2K0159D
C345	283-0178-00			CAP.,FXD,CER DI:0.1UF,+80-20%,100V	72982	8131N145651104Z
C346	283-0178-00			CAP.,FXD,CER DI:0.1UF,+80-20%,100V	72982	8131N145651104Z
C348	283-0003-00			CAP.,FXD,CER DI:0.01UF,+80-20%,150V	72982	855-547E103Z
C367	283-0010-00			CAP.,FXD,CER DI:0.05UF,+100-20%,50V	56289	273C20
C369	290-0522-00			CAP.,FXD,ELCTLT:1UF,20%,50V	56289	196D105X0050HAL
C375	283-0010-00			CAP.,FXD,CER DI:0.05UF,+100-20%,50V	56289	273C20
C378	290-0410-00			CAP.,FXD,ELCTLT:15UF,+50-10%,100V	56289	30D156F100DD4
C380	285-0629-00			CAP.,FXD,PLSTC:0.047UF,20%,100V	56289	410P47301
C382	290-0410-00			CAP.,FXD,ELCTLT:15UF,+50-10%,100V	56289	30D156F100DD4
C384	283-0267-00			CAP.,FXD,CER DI:0.01UF,20%,500V	72982	841-541C103M
C385	283-0267-00			CAP.,FXD,CER DI:0.01UF,20%,500V	72982	841-541C103M
C387	283-0267-00			CAP.,FXD,CER DI:0.01UF,20%,500V	72982	841-541C103M
C388	283-0267-00			CAP.,FXD,CER DI:0.01UF,20%,500V	72982	841-541C103M
C390	283-0267-00			CAP.,FXD,CER DI:0.01UF,20%,500V	72982	841-541C103M
C391	283-0267-00			CAP.,FXD,CER DI:0.01UF,20%,500V	72982	841-541C103M
C392	283-0013-00			CAP.,FXD,CER DI:0.01UF,+100-0%,1000V	56289	33C29A7
C394	283-0013-00			CAP.,FXD,CER DI:0.01UF,+100-0%,1000V	56289	33C29A7
C395	283-0013-00			CAP.,FXD,CER DI:0.01UF,+100-0%,1000V	56289	33C29A7
C397	283-0013-00			CAP.,FXD,CER DI:0.01UF,+100-0%,1000V	56289	33C29A7
C408	283-0279-00			CAP.,FXD,CER DI:0.001UF,20%,3000V	72982	878Y5S102M

Electrical Parts List—SC 501

Ckt No.	Tektronix Part No.	Serial/Model No. Eff Dscont	Name & Description	Mfr Code	Mfr Part Number
C412	290-0522-00		CAP., FXD, ELCTLT: 1UF, 20%, 50V	56289	196D105X0050HA1
C415	283-0343-00		CAP., FXD, CER DI: 0.01UF, 20%, 2000V	72982	3848-019E103M
C418	283-0279-00		CAP., FXD, CER DI: 0.001UF, 20%, 3000V	72982	878Y5S102M
C420	290-0164-00		CAP., FXD, ELCTLT: 1UF, +50-10%, 150V	56289	30D105F150BA4
C422	281-0638-00		CAP., FXD, CER DI: 240PF, 5%, 500V	72982	301-000Z5D0241J
C424	283-0057-00		CAP., FXD, CER DI: 0.1UF, +80-20%, 200V	56289	274C10
C505	281-0638-00		CAP., FXD, CER DI: 240PF, 5%, 500V	72982	301-000Z5D0241J
C514	290-0525-00		CAP., FXD, ELCTLT: 4.7UF, 20%, 50V	56289	196D475X0050KA1
C520	290-0525-00		CAP., FXD, ELCTLT: 4.7UF, 20%, 50V	56289	196D475X0050KA1
C525	290-0525-00		CAP., FXD, ELCTLT: 4.7UF, 20%, 50V	56289	196D475X0050KA1
C527	290-0525-00		CAP., FXD, ELCTLT: 4.7UF, 20%, 50V	56289	196D475X0050KA1
C530	290-0525-00		CAP., FXD, ELCTLT: 4.7UF, 20%, 50V	56289	196D475X0050KA1
C537	290-0525-00		CAP., FXD, ELCTLT: 4.7UF, 20%, 50V	56289	196D475X0050KA1
C540	281-0638-00		CAP., FXD, CER DI: 240PF, 5%, 500V	72982	301-000Z5D0241J
CR121	152-0246-00		SEMICOND DEVICE: SILICON, 400PIV, 200MA	07910	CD12676
CR125	152-0141-02		SEMICOND DEVICE: SILICON, 30V, 150MA	07910	1N4152
CR152	152-0141-02		SEMICOND DEVICE: SILICON, 30V, 150MA	07910	1N4152
CR154	152-0141-02		SEMICOND DEVICE: SILICON, 30V, 150MA	07910	1N4152
CR165	152-0233-00		SEMICOND DEVICE: SILICON, 85V, 100MA	07910	CD61128
CR178	152-0233-00		SEMICOND DEVICE: SILICON, 85V, 100MA	07910	CD61128
CR190	152-0141-02		SEMICOND DEVICE: SILICON, 30V, 150MA	07910	1N4152
CR200	152-0141-02		SEMICOND DEVICE: SILICON, 30V, 150MA	07910	1N4152
CR201	152-0141-02		SEMICOND DEVICE: SILICON, 30V, 150MA	07910	1N4152
CR215	152-0141-02		SEMICOND DEVICE: SILICON, 30V, 150MA	07910	1N4152
CR238	152-0141-02		SEMICOND DEVICE: SILICON, 30V, 150MA	07910	1N4152
CR280	152-0141-02		SEMICOND DEVICE: SILICON, 30V, 150MA	07910	1N4152
CR282	152-0141-02		SEMICOND DEVICE: SILICON, 30V, 150MA	07910	1N4152
CR285	152-0061-00		SEMICOND DEVICE: SILICON, 175V, 100MA	80009	152-0061-00
CR290	152-0061-00		SEMICOND DEVICE: SILICON, 175V, 100MA	80009	152-0061-00
CR334	152-0141-02		SEMICOND DEVICE: SILICON, 30V, 150MA	07910	1N4152
CR362	152-0141-02		SEMICOND DEVICE: SILICON, 30V, 150MA	07910	1N4152
CR365	152-0141-02		SEMICOND DEVICE: SILICON, 30V, 150MA	07910	1N4152
CR366	152-0141-02		SEMICOND DEVICE: SILICON, 30V, 150MA	07910	1N4152
CR382	152-0107-00		SEMICOND DEVICE: SILICON, 375V, 400MA	80009	152-0107-00
CR384	152-0107-00		SEMICOND DEVICE: SILICON, 375V, 400MA	80009	152-0107-00
CR386	152-0107-00		SEMICOND DEVICE: SILICON, 375V, 400MA	80009	152-0107-00
CR387	152-0107-00		SEMICOND DEVICE: SILICON, 375V, 400MA	80009	152-0107-00
CR389	152-0107-00		SEMICOND DEVICE: SILICON, 375V, 400MA	80009	152-0107-00
CR390	152-0107-00		SEMICOND DEVICE: SILICON, 375V, 400MA	80009	152-0107-00
CR392	152-0107-00		SEMICOND DEVICE: SILICON, 375V, 400MA	80009	152-0107-00
CR415	152-0107-00		SEMICOND DEVICE: SILICON, 375V, 400MA	80009	152-0107-00
CR416	152-0107-00		SEMICOND DEVICE: SILICON, 375V, 400MA	80009	152-0107-00
CR418	152-0107-00		SEMICOND DEVICE: SILICON, 375V, 400MA	80009	152-0107-00
CR420	152-0107-00		SEMICOND DEVICE: SILICON, 375V, 400MA	80009	152-0107-00
CR424	152-0107-00		SEMICOND DEVICE: SILICON, 375V, 400MA	80009	152-0107-00
CR540	152-0141-02		SEMICOND DEVICE: SILICON, 30V, 150MA	07910	1N4152
DS515	150-0109-00		LAMP, INCAND: 18V, 26MA	71744	CM7220
J100	131-0955-00		CONNECTOR, RCPT, :BNC, FEMALE	24931	28JR200-1
J101	355-0170-00		STUD, SHOULDERED: 6-32 X 0.40 INCH LONG	80009	355-0170-00

L415¹

P415¹

¹Furnished as a unit with V415.

Ckt No.	Tektronix Part No.	Serial/Model No. Eff	Dscont	Name & Description	Mfr Code	Mfr Part Number
Q120A,B	151-1011-00			TRANSISTOR:SILICON,JFE,N-CHANNEL,DUAL	22229	FD1167
Q125	151-0190-00			TRANSISTOR:SILICON,NPN	04713	2N3904
Q135	151-0190-00			TRANSISTOR:SILICON,NPN	04713	2N3904
Q148	151-0190-00			TRANSISTOR:SILICON,NPN	04713	2N3904
Q150	151-0188-00			TRANSISTOR:SILICON,PNP	04713	2N3906
Q158	151-0188-00			TRANSISTOR:SILICON,PNP	04713	2N3906
Q160	151-0190-00			TRANSISTOR:SILICON,NPN	04713	2N3904
Q165	151-0279-00			TRANSISTOR:SILICON,NPN	07263	S25381
Q167	151-0190-00			TRANSISTOR:SILICON,NPN	04713	2N3904
Q176	151-0190-00			TRANSISTOR:SILICON,NPN	04713	2N3904
Q178	151-0279-00			TRANSISTOR:SILICON,NPN	07263	S25381
Q184	151-0342-00			TRANSISTOR:SILICON,PNP	07263	2N4249
Q190	151-0341-00			TRANSISTOR:SILICON,NPN	07263	2N3565
Q230A,B	151-1054-00			TRANSISTOR:SILICON,JFE,N-CHANNEL,DUAL	22229	FD1644
Q240	151-0190-00			TRANSISTOR:SILICON,NPN	04713	2N3904
Q250	151-0190-00			TRANSISTOR:SILICON,NPN	04713	2N3904
Q252	151-0342-00			TRANSISTOR:SILICON,PNP	07263	2N4249
Q270	151-0342-00			TRANSISTOR:SILICON,PNP	07263	2N4249
Q285	151-0347-00			TRANSISTOR:SILICON,NPN	80009	151-0347-00
Q290	151-0347-00			TRANSISTOR:SILICON,NPN	80009	151-0347-00
Q305A,B	151-1054-00			TRANSISTOR:SILICON,JFE,N-CHANNEL,DUAL	22229	FD1644
Q315	151-0341-00			TRANSISTOR:SILICON,NPN	07263	2N3565
Q320	151-0341-00			TRANSISTOR:SILICON,NPN	07263	2N3565
Q336	151-0342-00			TRANSISTOR:SILICON,PNP	07263	2N4249
Q345	151-0350-00			TRANSISTOR:SILICON,PNP	07263	2N5401
Q348	151-0347-00			TRANSISTOR:SILICON,NPN	80009	151-0347-00
Q350	151-0301-00			TRANSISTOR:SILICON,PNP	04713	2N2907A
Q360	151-0519-00			TRANSISTOR:SILICON,SCR	04713	2N5063
Q365	151-0254-00			TRANSISTOR:SILICON,NPN	03508	2N5308
Q370	151-0301-00			TRANSISTOR:SILICON,PNP	04713	2N2907A
Q380	151-0358-00			TRANSISTOR:SILICON,NPN,SEL FROM D44R4	03508	D44R211
Q500	151-0190-00			TRANSISTOR:SILICON,NPN	04713	2N3904
Q510	151-0342-00			TRANSISTOR:SILICON,PNP	07263	2N4249
Q520	151-0208-00			TRANSISTOR:SILICON,PNP	12040	2N4036
Q525	151-0341-00			TRANSISTOR:SILICON,NPN	07263	2N3565
Q530	151-0342-00			TRANSISTOR:SILICON,PNP	07263	2N4249
Q535	151-0136-00			TRANSISTOR:SILICON,NPN	02735	35495
Q540	151-0342-00			TRANSISTOR:SILICON,PNP	07263	2N4249
Q545	151-0341-00			TRANSISTOR:SILICON,NPN	07263	2N3565
R100	315-0201-02			RES.,FXD,COMP:200 OHM,5%,0.25W	01121	CB2015
R105	322-0621-00			RES.,FXD,FILM:900K OHM,1%,0.25W	75042	CEBT0-9003F
R107	321-0617-00			RES.,FXD,FILM:111K OHM,1%,0.125W	75042	CEAT0-1113F
R113	322-0624-00			RES.,FXD,FILM:990K OHM,1%,0.25W	75042	CEBT0-9903F
R115	321-0614-00			RES.,FXD,FILM:10.1K OHM,1%,0.125W	75042	CEAT0-1012F
R117	321-0481-00			RES.,FXD,FILM:1M OHM,1%,0.125W	75042	CEAT0-1004F
R120	315-0104-00			RES.,FXD,COMP:100K OHM,5%,0.25W	01121	CB1045
R121	315-0201-00			RES.,FXD,COMP:200 OHM,5%,0.25W	01121	CB2015
R125	321-0184-00			RES.,FXD,FILM:806 OHM,1%,0.125W	75042	CEAT0-8060F
R127	321-0242-00			RES.,FXD,FILM:3.24K OHM,1%,0.125W	75042	CEAT0-3241F
R129	321-0086-00			RES.,FXD,FILM:76.8 OHM,1%,0.125W	75042	CEAT0-76R80F
R130	311-1182-00			RES.,VAR,NONWIR:1.5K OHM,10%,0.50W	01121	W-7835
R132	311-1560-00			RES.,VAR,NONWIR:5K OHM,5%,0.50W	73138	91A-5000M
R134	321-0242-00			RES.,FXD,FILM:3.24K OHM,1%,0.125W	75042	CEAT0-3241F
R136	321-0181-00			RES.,FXD,FILM:750 OHM,1%,0.125W	75042	CEAT0-7500F

Electrical Parts List—SC 501

Ckt No.	Tektronix Part No.	Serial/Model No. Eff	Model No. Dscont	Name & Description	Mfr Code	Mfr Part Number
R138	315-0560-00			RES.,FXD,COMP:56 OHM,5%,0.25W	01121	CB5605
R139	315-0472-00			RES.,FXD,COMP:4.7K OHM,5%,0.25W	01121	CB4725
R142	311-1558-00			RES.,VAR,NONWIR:20K OHM,20%,0.50W	73138	91A-20001M
R145	311-1298-00			RES.,VAR,NONWIR:10K OHM,20%,0.50W	01121	W-7909
R146	315-0622-00			RES.,FXD,COMP:6.2K OHM,5%,0.25W	01121	CB6225
R147	315-0155-00			RES.,FXD,COMP:1.5M OHM,5%,0.25W	01121	CB1555
R148	315-0103-00			RES.,FXD,COMP:10K OHM,5%,0.25W	01121	CB1035
R150	321-0221-00			RES.,FXD,FILM:1.96K OHM,1%,0.125W	75042	CEAT0-1961F
R152	321-0230-00			RES.,FXD,FILM:2.43K OHM,1%,0.125W	75042	CEAT0-2431F
R154	321-0155-00			RES.,FXD,FILM:402 OHM,1%,0.125W	75042	CEAT0-4020F
R156	321-0230-00			RES.,FXD,FILM:2.43K OHM,1%,0.125W	75042	CEAT0-2431F
R158	321-0221-00			RES.,FXD,FILM:1.96K OHM,1%,0.125W	75042	CEAT0-1961F
R160	315-0103-00			RES.,FXD,COMP:10K OHM,5%,0.25W	01121	CB1035
R165	308-0293-00	B010100	B039999	RES.,FXD,WW:4K OHM,5%,3W	91637	RS2B-B40000J
R165	308-0349-00	B040000		RES.,FXD,WW:3.6K OHM,1%,3W	91637	RS2B-B36000F
R167	322-0210-00	B010100	B039999	RES.,FXD,FILM:1.5K OHM,1%,0.25W	75042	CEBT0-1501F
R167	322-0205-00	B040000		RES.,FXD,FILM:1.33K OHM,1%,0.25W	75042	CEBT0-1331F
R169	321-0184-00			RES.,FXD,FILM:806 OHM,1%,0.125W	75042	CEAT0-8060F
R172	311-1563-00			RES.,VAR,NONWIR:1K OHM,20%,0.50W	73138	91A-10000M
R174	315-0392-00			RES.,FXD,COMP:3.9K OHM,5%,0.25W	01121	CB3925
R176	322-0210-00	B010100	B039999	RES.,FXD,FILM:1.5K OHM,1%,0.25W	75042	CEBT0-1501F
R176	322-0205-00	B040000		RES.,FXD,FILM:1.33K OHM,1%,0.25W	75042	CEBT0-1331F
R178	308-0293-00	B010100	B039999	RES.,FXD,WW:4K OHM,5%,3W	91637	RS2B-B40000J
R178	308-0349-00	B040000		RES.,FXD,WW:3.6K OHM,1%,3W	91637	RS2B-B36000F
R184	315-0622-00			RES.,FXD,COMP:6.2K OHM,5%,0.25W	01121	CB6225
R186	311-1565-00			RES.,VAR,NONWIR:250 OHM,20%,0.50W	73138	91A250ROM
R187	315-0331-00			RES.,FXD,COMP:330 OHM,5%,0.25W	01121	CB3315
R189	315-0561-00			RES.,FXD,COMP:560 OHM,5%,0.25W	01121	CB5615
R190	315-0182-00			RES.,FXD,COMP:1.8K OHM,5%,0.25W	01121	CB1825
R192	315-0272-00			RES.,FXD,COMP:2.7K OHM,5%,0.25W	01121	CB2725
R200	315-0223-00			RES.,FXD,COMP:22K OHM,5%,0.25W	01121	CB2235
R205	315-0332-00			RES.,FXD,COMP:3.3K OHM,5%,0.25W	01121	CB3325
R210	311-1686-00			RES.,VAR,NONWIR:2.5K OHM,20%,1W	01121	12M358
R212	311-1559-00			RES.,VAR,NONWIR:10K OHM,20%,0.50W	73138	91A-10001M
R214	315-0333-00			RES.,FXD,COMP:33K OHM,5%,0.25W	01121	CB3335
R215	315-0122-00			RES.,FXD,COMP:1.2K OHM,5%,0.25W	01121	CB1225
R220	315-0223-00			RES.,FXD,COMP:22K OHM,5%,0.25W	01121	CB2235
R225	311-1686-00			RES.,VAR,NONWIR:2.5K OHM,20%,1W	01121	12M358
R226	311-1564-00			RES.,VAR,NONWIR:500 OHM,20%,0.50W	73138	91A-500ROM
R228	321-0368-00			RES.,FXD,FILM:66.5K OHM,1%,0.125W	75042	CEAT0-6652F
R229	322-0464-00			RES.,FXD,FILM:665K OHM,1%,0.25W	75042	CEBT0-6653F
R230	323-0557-08			RES.,FXD,FILM:6.19M OHM,1%,0.50W	75042	CECT2-6194F
R231	321-0450-00			RES.,FXD,FILM:475K OHM,1%,0.125W	75042	CEAT0-4753F
R235	311-1558-00			RES.,VAR,NONWIR:20K OHM,20%,0.50W	73138	91A-20001M
R236	315-0433-00			RES.,FXD,COMP:43K OHM,5%,0.25W	01121	CB4335
R238	315-0432-00			RES.,FXD,COMP:4.3K OHM,5%,0.25W	01121	CB4325
R240	315-0103-00			RES.,FXD,COMP:10K OHM,5%,0.25W	01121	CB1035
R242	315-0303-00			RES.,FXD,COMP:30K OHM,5%,0.25W	01121	CB3035
R245	311-1558-00			RES.,VAR,NONWIR:20K OHM,20%,0.50W	73138	91A-20001M
R248	315-0562-00			RES.,FXD,COMP:5.6K OHM,5%,0.25W	01121	CB5625
R250	315-0103-00			RES.,FXD,COMP:10K OHM,5%,0.25W	01121	CB1035
R251	315-0471-00			RES.,FXD,COMP:470 OHM,5%,0.25W	01121	CB4715
R252	321-0246-00			RES.,FXD,FILM:3.57K OHM,1%,0.125W	75042	CEAT0-3571F
R254	321-0259-00			RES.,FXD,FILM:4.87K OHM,1%,0.125W	12697	MFF1816G48700F
R256	315-0512-00			RES.,FXD,COMP:5.1K OHM,5%,0.25W	01121	CB5125
R258	311-1564-00			RES.,VAR,NONWIR:500 OHM,20%,0.50W	73138	91A-500ROM
R260	315-0821-00			RES.,FXD,COMP:820 OHM,5%,0.25W	01121	CB8215
R265	311-1561-00			RES.,VAR,NONWIR:2.5K OHM,20%,0.50W	73138	91A-25000M
R267	321-0259-00			RES.,FXD,FILM:4.87K OHM,1%,0.125W	12697	MFF1816G48700F

Ckt No.	Tektronix Part No.	Serial/Model No. Eff	Dscont	Name & Description	Mfr Code	Mfr Part Number
R270	321-0246-00			RES.,FXD,FILM:3.57K OHM,1%,0.125W	75042	CEATO-3571F
R272	315-0222-00			RES.,FXD,COMP:2.2K OHM,5%,0.25W	01121	CB2225
R273	315-0912-00			RES.,FXD,COMP:9.1K OHM,5%,0.25W	01121	CB9125
R275	311-1298-00			RES.,VAR,NONWIR:10K OHM,20%,0.50W	01121	W7909
R280	315-0102-00			RES.,FXD,COMP:1K OHM,5%,0.25W	01121	CB1025
R285	308-0412-00			RES.,FXD,WW:8.2K OHM,1%,3W	91637	RS288201F
R287	321-0243-00			RES.,FXD,FILM:3.32K OHM,1%,0.125W	75042	CEATO-3321F
R289	321-0193-00			RES.,FXD,FILM:1K OHM,1%,0.125W	75042	CEATO-1001F
R291	321-0243-00			RES.,FXD,FILM:3.32K OHM,1%,0.125W	75042	CEATO-3321F
R294	308-0412-00			RES.,FXD,WW:8.2K OHM,1%,3W	91637	RS288201F
R300	311-1555-00			RES.,VAR,NONWIR:100K OHM,20%,0.5W	73138	91A-10002M
R302	315-0153-00			RES.,FXD,COMP:15K OHM,5%,0.25W	01121	CB1535
R303	315-0512-00			RES.,FXD,COMP:5.1K OHM,5%,0.25W	01121	CB5125
R305	315-0392-00			RES.,FXD,COMP:3.9K OHM,5%,0.25W	01121	CB3925
R307	315-0332-00			RES.,FXD,COMP:3.3K OHM,5%,0.25W	01121	CB3325
R310	315-0243-00			RES.,FXD,COMP:24K OHM,5%,0.25W	01121	CB2435
R315	315-0273-00			RES.,FXD,COMP:27K OHM,5%,0.25W	01121	CB2735
R316	315-0273-00			RES.,FXD,COMP:27K OHM,5%,0.25W	01121	CB2735
R318	315-0103-00			RES.,FXD,COMP:10K OHM,5%,0.25W	01121	CB1035
R320	315-0222-00			RES.,FXD,COMP:2.2K OHM,5%,0.25W	01121	CB2225
R324	321-0226-00			RES.,FXD,FILM:2.21K OHM,1%,0.125W	75042	CEATO-2211F
R326	321-0298-00			RES.,FXD,FILM:12.4K OHM,1%,0.125W	75042	CEATO-1242F
R328	315-0113-00			RES.,FXD,COMP:11K OHM,5%,0.25W	01121	CB1135
R330	311-1298-00			RES.,VAR,NONWIR:10K OHM,20%,0.50W	01121	W7909
R334	315-0184-00			RES.,FXD,COMP:180K OHM,5%,0.25W	01121	CB1845
R336	315-0222-00			RES.,FXD,COMP:2.2K OHM,5%,0.25W	01121	CB2225
R337	315-0472-00			RES.,FXD,COMP:4.7K OHM,5%,0.25W	01121	CB4725
R339	321-0344-00			RES.,FXD,FILM:37.4K OHM,1%,0.125W	75042	CEATO-3742F
R342	315-0683-00			RES.,FXD,COMP:68K OHM,5%,0.25W	01121	CB6835
R343	315-0682-00			RES.,FXD,COMP:6.8K OHM,5%,0.25W	01121	CB6825
R345	315-0471-00			RES.,FXD,COMP:470 OHM,5%,0.25W	01121	CB4715
R346	315-0182-00			RES.,FXD,COMP:1.8K OHM,5%,0.25W	01121	CB1825
R348	315-0101-00			RES.,FXD,COMP:100 OHM,5%,0.25W	01121	CB1015
R352	315-0102-00			RES.,FXD,COMP:1K OHM,5%,0.25W	01121	CB1025
R354	315-0472-00			RES.,FXD,COMP:4.7K OHM,5%,0.25W	01121	CB4725
R356	315-0183-00			RES.,FXD,COMP:18K OHM,5%,0.25W	01121	CB1835
R357	315-0102-00			RES.,FXD,COMP:1K OHM,5%,0.25W	01121	CB1025
R362	321-0645-00			RES.,FXD,FILM:100K OHM,0.5%,0.125W	75042	CEAT2100KD
R363	315-0102-00			RES.,FXD,COMP:1K OHM,5%,0.25W	01121	CB1025
R365	315-0103-00			RES.,FXD,COMP:10K OHM,5%,0.25W	01121	CB1035
R367	315-0103-00			RES.,FXD,COMP:10K OHM,5%,0.25W	01121	CB1035
R369	315-0101-00			RES.,FXD,COMP:100 OHM,5%,0.25W	01121	CB1015
R370	315-0222-00			RES.,FXD,COMP:2.2K OHM,5%,0.25W	01121	CB2225
R372	315-0682-00			RES.,FXD,COMP:6.8K OHM,5%,0.25W	01121	CB6825
R374	315-0472-00			RES.,FXD,COMP:4.7K OHM,5%,0.25W	01121	CB4725
R375	315-0101-00			RES.,FXD,COMP:100 OHM,5%,0.25W	01121	CB1015
R378	315-0100-00			RES.,FXD,COMP:10 OHM,5%,0.25W	01121	CB1005
R380	315-0100-00			RES.,FXD,COMP:10 OHM,5%,0.25W	01121	CB1005
R382	315-0220-00			RES.,FXD,COMP:22 OHM,5%,0.25W	01121	CB2205
R392	315-0822-00			RES.,FXD,COMP:8.2K OHM,5%,0.25W	01121	CB8225
R395	315-0203-00			RES.,FXD,COMP:20K OHM,5%,0.25W	01121	CB2035
R397	315-0100-00			RES.,FXD,COMP:10 OHM,5%,0.25W	01121	CB1005
R398	315-0100-00			RES.,FXD,COMP:10 OHM,5%,0.25W	01121	CB1005
R400	321-0481-00			RES.,FXD,FILM:1M OHM,1%,0.125W	75042	CEATO-1004F
R402	321-0481-00			RES.,FXD,FILM:1M OHM,1%,0.125W	75042	CEATO-1004F

Electrical Parts List—SC 501

Ckt No.	Tektronix Part No.	Serial/Model No. Eff	Dscont	Name & Description	Mfr Code	Mfr Part Number
R405	311-1312-00			RES., VAR, NONWIR: 5M OHM, 20%, 1W	01121	10M156A
R406	321-0481-00			RES., FXD, FILM: 1M OHM, 1%, 0.125W	75042	CEATO-1004F
R407	321-0481-00			RES., FXD, FILM: 1M OHM, 1%, 0.125W	75042	CEATO-1004F
R408	321-0481-00			RES., FXD, FILM: 1M OHM, 1%, 0.125W	75042	CEATO-1004F
R410	315-0106-00			RES., FXD, COMP: 10M OHM, 5%, 0.25W	01121	CB1065
R412	321-0377-00			RES., FXD, FILM: 82.5K OHM, 1%, 0.125W	75042	CEATO-8252F
R413	321-0354-00			RES., FXD, FILM: 47.5K OHM, 1%, 0.125W	75042	CEATO-4752F
R414	315-0822-00			RES., FXD, COMP: 8.2K OHM, 5%, 0.25W	01121	CB8225
R415	311-1558-00			RES., VAR, NONWIR: 20K OHM, 20%, 0.50W	73138	91A-20001M
R422	315-0334-00			RES., FXD, COMP: 330K OHM, 5%, 0.25W	01121	CB3345
R424	315-0222-00			RES., FXD, COMP: 2.2K OHM, 5%, 0.25W	01121	CB2225
R425	311-1554-00			RES., VAR, NONWIR: 200K OHM, 20%, 0.50W	73138	91A-20002M
R500	311-1564-00			RES., VAR, NONWIR: 500 OHM, 20%, 0.50W	73138	91A-500ROM
R501	321-0222-00			RES., FXD, FILM: 2K OHM, 1%, 0.125W	75042	CEATO-2001F
R502	321-0252-00			RES., FXD, FILM: 4.12K OHM, 1%, 0.125W	75042	CEATO-4121F
R504	315-0222-00			RES., FXD, COMP: 2.2K OHM, 5%, 0.25W	01121	CB2225
R506	315-0102-00			RES., FXD, COMP: 1K OHM, 5%, 0.25W	01121	CB1025
R507	315-0621-00			RES., FXD, COMP: 620 OHM, 5%, 0.25W	01121	CB6215
R510	315-0822-00			RES., FXD, COMP: 8.2K OHM, 5%, 0.25W	01121	CB8225
R512	307-0115-00			RES., FXD, COMP: 7.5 OHM, 5%, 0.25W	01121	CB75G5
R514	315-0201-00			RES., FXD, COMP: 200 OHM, 5%, 0.25W	01121	CB2015
R518	308-0218-00			RES., FXD, WW: 150 OHM, 5%, 3W	56289	242E151J
R520	315-0102-00			RES., FXD, COMP: 1K OHM, 5%, 0.25W	01121	CB1025
R522	321-0237-00			RES., FXD, FILM: 2.87K OHM, 1%, 0.125W	75042	CEATO-2871F
R523	321-0226-00			RES., FXD, FILM: 2.21K OHM, 1%, 0.125W	75042	CEATO-2211F
R525	315-0121-00			RES., FXD, COMP: 120 OHM, 5%, 0.25W	01121	CB1215
R527	315-0121-00			RES., FXD, COMP: 120 OHM, 5%, 0.25W	01121	CB1215
R532	321-0226-00			RES., FXD, FILM: 2.21K OHM, 1%, 0.125W	75042	CEATO-2211F
R533	321-0237-00			RES., FXD, FILM: 2.87K OHM, 1%, 0.125W	75042	CEATO-2871F
R535	315-0102-00			RES., FXD, COMP: 1K OHM, 5%, 0.25W	01121	CB1025
R537	308-0385-00			RES., FXD, WW: 200 OHM, 5%, 3W	63743	35326
R540	315-0622-00			RES., FXD, COMP: 6.2K OHM, 5%, 0.25W	01121	CB6225
R542	321-0289-00			RES., FXD, FILM: 10K OHM, 1%, 0.125W	75042	CEATO-1002F
R543	321-0289-00			RES., FXD, FILM: 10K OHM, 1%, 0.125W	75042	CEATO-1002F
R545	315-0102-00			RES., FXD, COMP: 1K OHM, 5%, 0.25W	01121	CB1025
R546	315-0621-00			RES., FXD, COMP: 620 OHM, 5%, 0.25W	01121	CB6215
R548	315-0822-00			RES., FXD, COMP: 8.2K OHM, 5%, 0.25W	01121	CB8225
R550	307-0109-00			RES., FXD, COMP: 8.2 OHM, 5%, 0.25W	01121	CB82G5
S100	260-1445-00			SWITCH, PUSH:	80009	260-1445-00
S110A, B	260-1365-00			SWITCH, PUSH:	80009	260-1365-00
S200	260-1470-00			SWITCH, SLIDE: DPDT, 0.5A, 125V	10389	23-021-309
S220A, B	260-1365-00			SWITCH, PUSH:	80009	260-1365-00
S225	260-1332-00			SWITCH, PUSH: 1 BUTTON, MS	71590	2KHB010010-XXX
S230	260-0723-00			SWITCH, SLIDE: DPDT, 0.5A, 125VAC	80009	260-0723-00
T380	120-0863-00			XFMP, PWR, SDN &: HV	80009	120-0863-00
U200	155-0055-00			MICROCIRCUIT LI: TRIG SWP	80009	155-0055-00
U310	156-0105-00			MICROCIRCUIT, LI: OPERATIONAL AMPLIFIER	27014	LM301AN
V415	154-0699-00			ELECTRON TUBE:	80009	154-0699-00
VR280	152-0279-00			SEMICONV DEVICE: ZENER, 0.4W, 5.1V, 5%	07910	1N751A
VR350	152-0283-00	B010100	B029999X	SEMICONV DEVICE: ZENER, 0.4W, 43V, 5%	04713	1N976B
VR352	152-0241-00	B010100	B029999	SEMICONV DEVICE: ZENER, 0.4W, 33V, 5%	04713	1N973B
VR352	152-0357-00	B030000		SEMICONV DEVICE: ZENER, 0.4W, 82V, 5%	04713	1N983B
VR500	152-0280-00			SEMICONV DEVICE: ZENER, 0.4W, 6.2V, 5%	04713	1N753A

CALIBRATION ADJUSTMENTS

SERVICES AVAILABLE

Tektronix, Inc., provides complete instrument repair and calibration at local Field Service Centers and at the Factory Service Center. Contact your local Tektronix Field Office or representative for further information.

NOTE

The test equipment and accessories required for complete calibration of the SC 501 are listed under Test Equipment Required. Do not proceed with VERTICAL or HORIZONTAL adjustments unless the checks and procedures for the POWER SUPPLY & CRT ADJUSTMENTS have been performed. The performance of this instrument can be checked at any temperature within the 0°C to +50°C range. Make any adjustment at a temperature of +25°C, ±5°C.

WARNING

Dangerous potentials exist at several points throughout this instrument. When the instrument is operated with the covers removed, do not touch exposed connections or components. Disconnect power before cleaning the instrument or replacing parts.

PRELIMINARY PROCEDURE

- Check that correct nominal line selector block has been installed on the line selector pins on the Power Module and that the regulating range selected includes the input line voltage. See Installation section of Power Module instruction manual.
- Remove the SC 501 side covers and connect the SC 501 to the Power Module using the plug-in extender.
- Connect the Power Module to the variable autotransformer and autotransformer to input line voltage. Set autotransformer to nominal line voltage and apply power to the SC 501.

d. Set the following controls on the SC 501.

INTENSITY	Fully counterclockwise (ccw).
FOCUS	Midrange
POSITION (Vertical)	Midrange
POSITION (Horizontal)	Midrange
VARIABLE (Vertical)	Fully clockwise (cw) (X1)
VARIABLE (Time base)	Fully clockwise (cw) (X1)
LEVEL/SLOPE	AUTO (Centered and pulled OUT)
Trigger Source	INT
Pushbuttons	ALL OUT, except ms pushed in.

POWER SUPPLY & CRT

1. Power Supply Checks

Connect the precision dc voltmeter between each voltage test point and ground. Check that each supply is within the tolerance listed below.

Supply	Tolerance
+20 V	+19.9 V to +20.1 V
-20 V	-19.6 V to -20.4 V
+8 V	+7.9 V to +8.5 V
-8 V	-7.8 V to -8.6 V
+65 V	+60 V to +70 V
-980 V	-950 V to -1010 V

2. +20 V Adjustment R500

Connect the precision dc voltmeter between the +20 V test point and ground. Adjust R500 (+20 V ADJ) for a reading of exactly +20 volts.

3. Regulation

With the dc voltmeter on the -980 V test point, adjust Variable Autotransformer output voltage from the low limit to the high limit as indicated in the Power Module instruction manual. Test point reading should not vary more than ±10 V. Return Variable Autotransformer to nominal line voltage setting.

4. CRT Bias Adjustment R425

With the INTENSITY control set fully ccw and no test equipment connected to the SC 501, adjust R425 (Bias) until trace just disappears. If trace is not visible, adjust R425 until trace appears and readjust R425 until trace just disappears.

5. Trace Rotation Adjustment R415

Adjust INTENSITY cw for visible trace, FOCUS for best trace, horizontal position for centered trace. Adjust R415 for straight line trace. Adjust vertical position control to set trace top to bottom of graticule. It may be necessary to readjust R415 so that trace will be a best straight line compromise at any vertical position.

VERTICAL SYSTEM

NOTE

Refer to POWER SUPPLY & CRT (steps 1-5) before performing any vertical system adjustments. Be certain that the power supply and crt voltages are within their listed tolerance and that all controls on the SC 501 have been set to their preliminary settings.

6. Vertical Balance R142

Set vertical deflection factor to 10 mV/div, AC COUPL in, and center the trace with POSITION controls. No input signal applied. Rotate vertical VARIABLE from X1 to X10 and note the position of the trace at X10 setting. Return vertical VARIABLE to X1 position. Adjust R142 (Bal) to set trace to same position as the VARIABLE X10 setting. Repeat the above procedure until there is one-half minor division or less of trace shift when rotating vertical VARIABLE over its entire range. Reset vertical VARIABLE to X1 position.

7. Trigger Balance R186

Attach probe of test oscilloscope to junction of R200, C200 and connection to trigger selector switch. Using the test oscilloscope as a dc voltmeter, adjust R186 for a reading of +50 mV. Apply a 50 mV, 1 kHz square wave from the Amplitude Calibrator to the VERT INPUT connector of the SC 501. Measure the peak-to-peak amplitude. Displayed signal on the test oscilloscope should be a square wave with a peak-to-peak amplitude not less than 2.8 volts nor more than 4.2 volts. Remove test oscilloscope probe from SC 501.

8. Vertical Gain (X1) and vertical VARIABLE range (X10)

With 50 mV square wave still applied, adjust SC 501 LEVEL/SLOPE control for stable display. Set vertical VARIABLE to X1 and adjust R172 (Vert Gain) for a display amplitude of exactly 5 major divisions. Set vertical VARIABLE to X10. Apply 500 mV square wave from Amplitude Calibrator. Adjust R132 (X10 Cal) for a display amplitude of exactly 5 major divisions. Remove Amplitude Calibrator signal. Set vertical VARIABLE to X1.

9. Normalize (10 mV/div) input time constant

Attach Input Normalizer (47 pF) to VERT INPUT connector. Set SC 501 controls to 10 mV/div, vertical VARIABLE to X1. Apply 100 mV, 1 kHz square wave from Amplitude Calibrator to Input Normalizer. Adjust C117 for best displayed square wave (flat top and square corners) on SC 501 crt. Remove Input Normalizer from circuit.

10. Normalize (100 mV/div) input time constant

Set SC 501 to 100 mV/div. Apply 500 mV, 1 kHz square wave from Amplitude Calibrator directly to VERT INPUT of SC 501. Check for displayed amplitude of 4.85 to 5.15 major divisions. Adjust C112 for best displayed square wave. Insert Input Normalizer between VERT INPUT connector and Amplitude Calibrator. Apply 1 V, 1 kHz square wave to Input Normalizer. Adjust C110 for best displayed square wave. Remove Input Normalizer from circuit.

11. Normalize (1 V/div) input time constant

Set SC 501 controls to 1 V/div. Apply 5 V, 1 kHz square wave from Amplitude Calibrator directly to VERT INPUT connector. Check for displayed amplitude of 4.85 to 5.15 major divisions. Adjust C104 for best displayed square wave. Insert Input Normalizer between VERT INPUT connector and Amplitude Calibrator. Apply 10 V, 1 kHz square wave to Input Normalizer. Adjust C102 for best displayed square wave. Remove Input Normalizer from circuit. Set SC 501 controls to 10 mV/div; dc coupled (all vertical pushbuttons OUT).

12. Check vertical bandwidth

Terminate VERT INPUT connector of SC 501 with 50-ohm termination. Set all SC 501 vertical pushbuttons to OUT position (10 mV/div; dc coupled).

a. Apply 50 kHz reference frequency from Leveled Sine-Wave Generator to 50-ohm termination and output for a displayed amplitude of 6.0 major divisions. Set Leveled Wave Generator frequency to 50 kHz. Displayed amplitude must be between 4.2 and 5.8 major divisions.

b. Repeat step 12a with SC 5 for 100 mV/div.

c. Repeat step 12a with SC 5 for 1 V/div. Use 5.0 major divisions displayed amplitude at the 50 kHz reference frequency. Displayed amplitude at 5 MHz must be greater than 3.5 divisions.

HORIZONTAL SYSTEM

NOTE

Refer to POWER SUPPLY & CRT (steps 1-5) before performing horizontal system adjustments. Be certain that the power supply and crt voltages are within their listed tolerance and that all controls on the SC 501 have been set to their preliminary settings.

13. Check Time/div accuracy

Apply appropriate time mark Time-Mark Generator to VERT connector on SC 501. Adjust controls so that second marker is second vertical graticule line. Check proper timing over the center division portion of the sweep for Time/div setting. Disregard the 0.5 microsecond of total sweep.

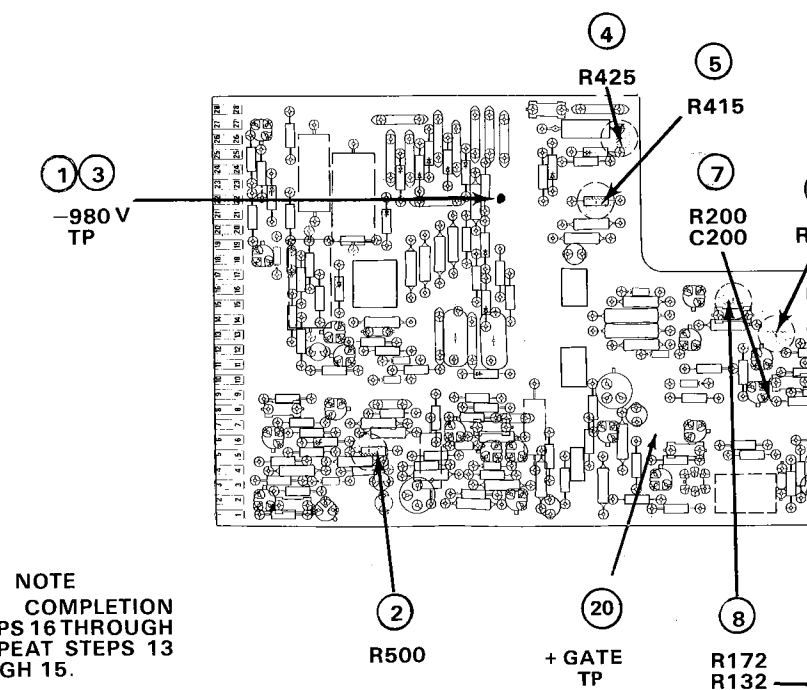
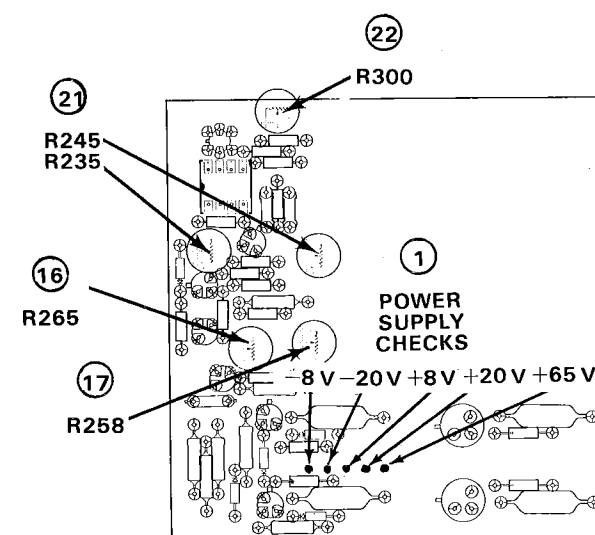

NOTE
AFTER COMPLETION OF STEPS 16 THROUGH 18, REPEAT STEPS 13 THROUGH 15.

CALIBRATION ADJUSTMENTS

5. Trace Rotation Adjustment R415

Adjust INTENSITY cw for visible trace, FOCUS for best trace, horizontal position for centered trace. Adjust R415 for straight line trace. Adjust vertical position control to set trace top to bottom of graticule. It may be necessary to readjust R415 so that trace will be a best straight line compromise at any vertical position.

7. Trigger Balance R186

Attach probe of test oscilloscope to junction of R200, C200 and connection to trigger selector switch. Using the test oscilloscope as a dc voltmeter, adjust R186 for a reading of +50 mV. Apply a 50 mV, 1 kHz square wave from the Amplitude Calibrator to the VERT INPUT connector of the SC 501. Measure the peak-to-peak amplitude. Displayed signal on the test oscilloscope should be a square wave with a peak-to-peak amplitude not less than 2.8 volts nor more than 4.2 volts. Remove test oscilloscope probe from SC 501.

10. Normalize (100 mV/div) input time constant

Set SC 501 to 100 mV/div. Apply 500 mV, 1 kHz square wave from Amplitude Calibrator directly to VERT INPUT of SC 501. Check for displayed amplitude of 4.85 to 5.15 major divisions. Adjust C112 for best displayed square wave. Insert Input Normalizer between VERT INPUT connector and Amplitude Calibrator. Apply 1 V, 1 kHz square wave to Input Normalizer. Adjust C110 for best displayed square wave. Remove Input Normalizer from circuit.

a. Apply 50 kHz reference signal frequency from Leveled Sine-Wave Generator to 50-ohm termination and adjust output for a displayed amplitude of 6.0 major divisions. Set Leveled Sine-Wave Generator frequency to 5 MHz. Displayed amplitude must be greater than 4.2 major divisions.

b. Repeat step 12a with SC 501 set for 100 mV/div.

c. Repeat step 12a with SC 501 set for 1 V/div. Use 5.0 major divisions of displayed amplitude at the 50 kHz reference frequency. Displayed amplitude at 5 MHz must be greater than 3.5 major divisions.

Time Marks	SC 501 Time/div	Tolerance
1 ms	1 ms/div	The second through tenth time marks displayed for each Time/div setting must be aligned with its associated vertical graticule line within ±2 minor divisions (5% of eight divisions).
10 ms	10 ms/div	
100 ms	100 ms/div	
1 μs	1 μs/div	
10 μs	10 μs/div	
100 μs	100 μs/div	

14. Check X5 Magnification

Apply 500 microsecond markers to SC 501 at 1 ms/div. Pull time base VARIABLE control out (X5). Five-division spacing between two time marks indicates X5 magnification. Push time base VARIABLE in and set to X1 position.

15. Check time base VARIABLE range

Apply 10 millisecond time marks to SC 501 at 1 ms/div. Set time base VARIABLE to X10 position. One time mark per division indicates a 10:1 range. Return time base VARIABLE to X1 position.

16. Adjust basic timing

Apply one millisecond time marks to SC 501 at 1 ms/div. Adjust R265 (Horizontal Gain X1) on Auxiliary board for nine divisions of horizontal deflection. Adjust R212 (Sweep Adj) to display a total of eleven time marks. Readjust R265 for one time mark per major division on the SC 501.

17. Adjust X5 Magnification

Apply 500 microsecond time marks to SC 501 at 1 ms/div. Pull time base VARIABLE control out (X5). Adjust R258 (horizontal Gain X5) for a display

of two time marks per five major divisions. Position display horizontally from full left to full right. Signal linearity must remain within ±2 minor divisions. Return horizontal POSITION control to midrange. Push time base VARIABLE control in and set to X1 position.

18. Adjust time base VARIABLE range

Apply 10 millisecond time marks to SC 501 at 1 ms/div. Set time base VARIABLE to X10 position. Adjust R226 (Sweep X10 Cal) for a display of one time mark per major division on the SC 501. Return time base VARIABLE to X1 position.

19. Check Trigger functions

Connect time marker output from the Time-Mark Generator to VERT INPUT of SC 501 and trigger output from Time-Mark Generator to EXT TRIG pin jack of SC 501. Set SC 501 trigger source to EXT and triggering mode to AUTO. Set SC 501 time base for 1 ms/div. Set time marks and triggers from Time-Mark Generator for 1 millisecond. Adjust LEVEL/SLOPE control for a stable display on SC 501. Keeping marker output of Time-Mark Generator at 1 millisecond: select in sequence, 10 millisecond, 0.1 second, and 1 second triggers from Time-Mark Generator. SC 501 display should not be stable for 1 second triggers in AUTO mode. Push LEVEL/SLOPE control in and check for a stable display with 1 second triggers. Adjustment of LEVEL/SLOPE control may be necessary.

20. Check + Gate Out

Set SC 501 time base for 1 ms/div. LEVEL/SLOPE out (AUTO). Trigger source to INT. No signals applied. Using test oscilloscope, check + Gate Out for a 10 millisecond rectangular pulse. Amplitude limits: 7.7 volts to 8.7 volts.

21. Adjust Ramp Out

With SC 501 controls set the same as for step 8, attach probe of test oscilloscope to pin 15A at rear interface connector. Using test oscilloscope as a voltmeter adjust R245 (Ramp Gain) for a 10 V peak-to-peak signal. Adjust R235 (Ramp Zero) for signal level to start at a zero volt dc level.

22. Adjust External Gain

Set SC 501 Ext Horiz (X-Y) selector switch, S230, toward rear of instrument. Adjust INTENSITY for visible dot on crt of SC 501. Position dot to first vertical line on left side of screen and centered vertically. Apply a 1 V, 1 kHz square wave from Amplitude Calibrator to EXT HORIZ pin jack on SC 501. Adjust R300 (Ext Gain) for 10 major divisions of horizontal deflection (100 mV/div).

VERTICAL SYSTEM

NOTE

Refer to POWER SUPPLY & CRT (steps 1-5) before performing any vertical system adjustments. Be certain that the power supply and crt voltages are within their listed tolerance and that all controls on the SC 501 have been set to their preliminary settings.

6. Vertical Balance R142

Set vertical deflection factor to 10 mV/div, AC COUPL in, and center the trace with POSITION controls. No input signal applied. Rotate vertical VARIABLE from X1 to X10 and note the position of the trace at X10 setting. Return vertical VARIABLE to X1 position. Adjust R142 (Bal) to set trace to same position as the VARIABLE X10 setting. Repeat the above procedure until there is one-half minor division or less of trace shift when rotating vertical VARIABLE over its entire range. Reset vertical VARIABLE to X1 position.

8. Vertical Gain (X1) and vertical VARIABLE range (X10)

With 50 mV square wave still applied, adjust SC 501 LEVEL/SLOPE control for stable display. Set vertical VARIABLE to X1 and adjust R172 (Vert Gain) for a display amplitude of exactly 5 major divisions. Set vertical VARIABLE to X10. Apply 500 mV square wave from Amplitude Calibrator. Adjust R132 (X10 Cal) for a display amplitude of exactly 5 major divisions. Remove Amplitude Calibrator signal. Set vertical VARIABLE to X1.

9. Normalize (10 mV/div) input time constant

Attach Input Normalizer (47 pF) to VERT INPUT connector. Set SC 501 controls to 10 mV/div, vertical VARIABLE to X1. Apply 100 mV, 1 kHz square wave from Amplitude Calibrator to Input Normalizer. Adjust C117 for best displayed square wave (flat top and square corners) on SC 501 crt. Remove Input Normalizer from circuit.

11. Normalize (1 V/div) input time constant

Set SC 501 controls to 1 V/div. Apply 5 V, 1 kHz square wave from Amplitude Calibrator directly to VERT INPUT connector. Check for displayed amplitude of 4.85 to 5.15 major divisions. Adjust C104 for best displayed square wave. Insert Input Normalizer between VERT INPUT connector and Amplitude Calibrator. Apply 10 V, 1 kHz square wave to Input Normalizer. Adjust C102 for best displayed square wave. Remove Input Normalizer from circuit. Set SC 501 controls to 10 mV/div; dc coupled (all vertical pushbuttons OUT).

12. Check vertical bandwidth

Terminate VERT INPUT connector of SC 501 with 50-ohm termination. Set all SC 501 vertical pushbuttons to OUT position (10 mV/div; dc coupled).

HORIZONTAL SYSTEM

NOTE

Refer to POWER SUPPLY & CRT (steps 1-5) before performing any horizontal system adjustments. Be certain that the power supply and crt voltages are within their listed tolerance and that all controls on the SC 501 have been set to their preliminary settings.

13. Check Time/div accuracy

Apply appropriate time marks from Time-Mark Generator to VERT INPUT connector on SC 501. Adjust SC 501 controls so that second marker is on the second vertical graticule line. Check for proper timing over the center eight division portion of the sweep for each Time/div setting. Disregard the first 0.5 microsecond of total sweep length.

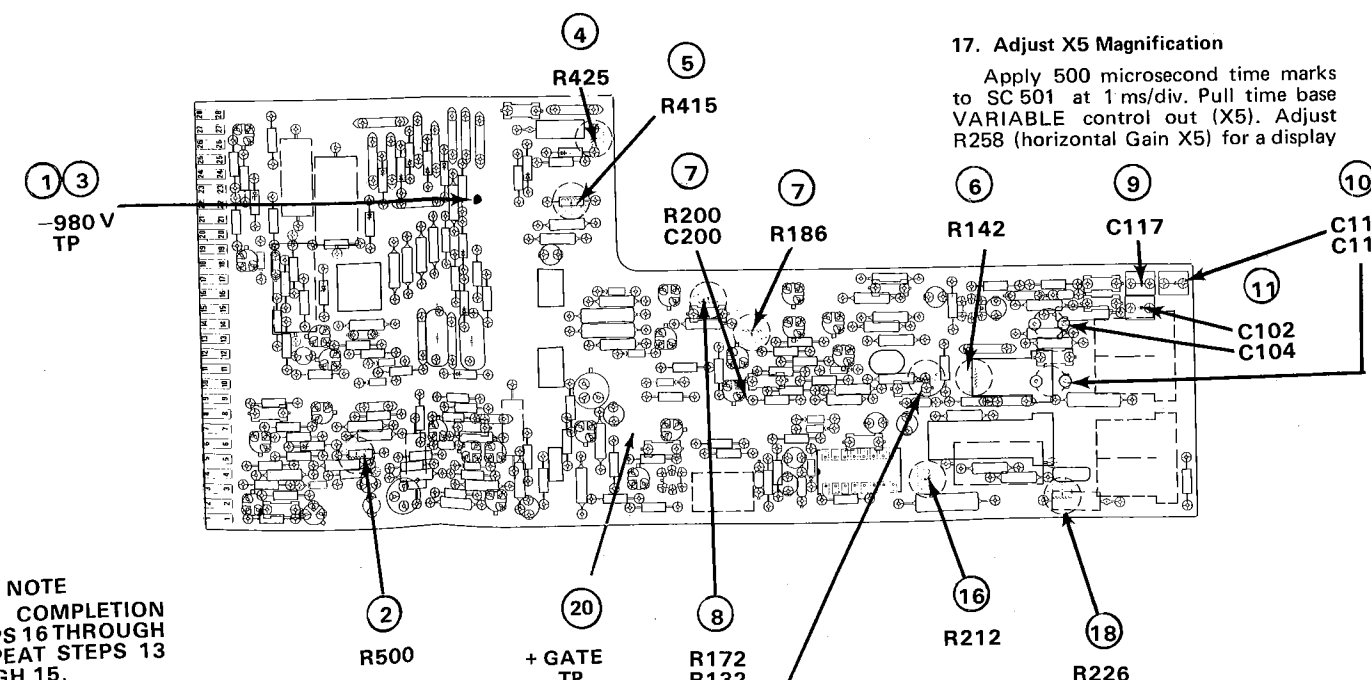
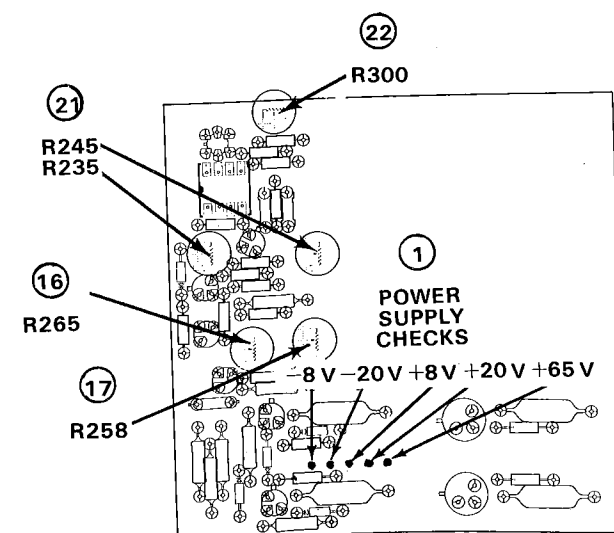

NOTE
AFTER COMPLETION OF STEPS 16 THROUGH 18, REPEAT STEPS 13 THROUGH 15.

clockwise

ise (cw) (X1)
ise (cw) (X1)
ered and
)

cept
in.

POWER SUPPLY & CRT

Power Supply Checks

Connect the precision dc voltmeter in each voltage test point and check that each supply is within tolerance listed below.

Supply	Tolerance
20 V	+19.9 V to +20.1 V
20 V	-19.6 V to -20.4 V
+8 V	+7.9 V to +8.5 V
-8 V	-7.8 V to -8.6 V
65 V	+60 V to +70 V
80 V	-950 V to -1010 V

0 V Adjustment R500

Connect the precision dc voltmeter between the +20 V test point and ground. Adjust R500 (+20 V ADJ) for a reading of exactly +20 volts.

Regulation

With the dc voltmeter on the -980 V point, adjust Variable Autotransformer output voltage from the low limit to the high limit as indicated in the Module instruction manual. Test the reading should not vary more than 0.5 V. Return Variable Autotransformer to minimal line voltage setting.

CRT Bias Adjustment R425

With the INTENSITY control set to minimum and no test equipment connected to the SC 501, adjust R425 until trace just disappears. If trace is not visible, adjust R425 until trace is visible, then adjust R425 until trace disappears.

MENTS

PARTS LOCATION GRID

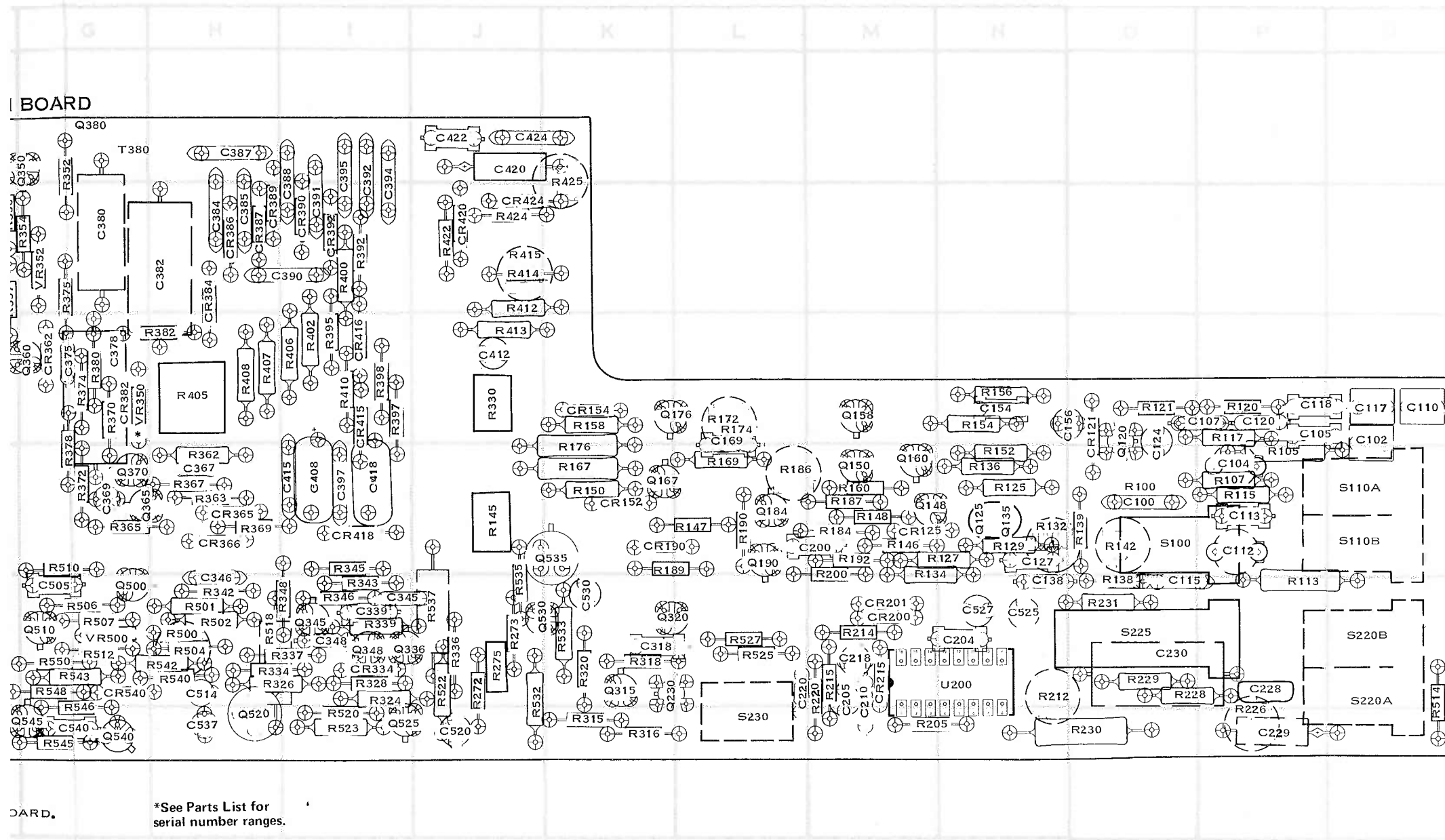

CKT NO	GRID LOC	CKT NO	GRID LOC
R336	J-5	R535	J-5
R337	H-5	R537	J-5
R339	I-5	R540	H-5
R342	H-5	R542	H-5
R343	I-5	R543	G-5
R345	I-4	R545	G-5
R346	I-5	R546	G-5
R348	I-5	R548	G-5
R352	G-1	R550	G-5
R354	G-2		
R356	F-2	S100	O-4
R357	F-2	S110	Q-4
R362	H-4	S220	Q-5
R363	H-4	S225	O-5
R365	G-4	S230	L-6
R367	H-4		
R369	H-4	T380	G-1
R370	G-3		
R372	G-4	U200	M-5
R374	G-3	U310	A-2
R375	G-2		
R378	F-4	VR280	B-5
R380	G-3	VR350	G-3
R382	H-3	VR352	G-2
R392	I-2	VR500	G-5
R395	I-3		
R397	I-3		
R398	I-3		
R400	I-2		
R402	I-3		
R405	H-3		
R406	I-3		
R407	H-3		
R408	H-3		
R410	I-3		
R412	J-2		
R413	J-3		
R414	J-2		
R415	J-2		
R422	J-2		
R424	J-2		
R425	K-1		
R500	H-5		
R501	H-5		
R502	H-5		
R504	H-5		
R506	G-5		
R507	G-5		
R510	G-4		
R512	G-5		
R514	Q-6		
R518	H-5		
R520	I-6		
R522	J-5		
R523	I-6		
R525	L-5		
R527	L-5		
R532	J-5		
R533	K-5		

CKT NO	GRID LOC	CKT NO	GRID LOC	CKT NO	GRID LOC	CKT NO	GRID LOC	CKT NO	GRID LOC	CKT NO	GRID LOC	CKT NO	GRID LOC	CKT NO	GRID LOC	CKT NO	GRID LOC	CKT NO	GRID LOC	CKT NO	GRID LOC	CKT NO	GRID LOC	CKT NO	GRID LOC		
CR280	B-5	CR387	H-2	Q120	O-3	Q184	L-4	Q320	K-5	Q520	H-6	R115	P-4	R139	O-4	R160	M-4	R189	K-4	R229	O-5	R251	D-1	R275	J-5	R307	B-2
CR282	A-5	CR389	H-2	Q125	N-4	Q190	L-4	Q336	I-5	Q525	I-6	R117	P-3	R142	O-4	R165	E-4	R190	L-4	R230	O-6	R252	A-5	R280	B-5	R310	B-2
CR285	B-5	CR390	I-2	Q135	N-4	Q230	K-5	Q345	I-5	Q530	J-5	R120	P-4	R145	J-4	R167	K-4	R192	M-4	R231	O-5	R254	A-5	R285	B-4	R315	K-6
CR290	B-5	CR392	I-2	Q148	M-4	Q240	A-3	Q348	I-5	Q535	K-4	R121	O-3	R146	M-4	R169	L-4	R200	M-4	R235	A-3	R256	B-3	R287	A-5	R316	K-6
CR334	I-5	CR415	I-3	Q150	M-4	Q250	B-3	Q350	G-1	Q540	G-6	R125	N-4	R147	L-4	R172	L-3	R205	M-6	R236	B-3	R258	B-4	R289	A-5	R318	K-5
CR362	G-3	CR416	I-3	Q158	M-3	Q252	A-4	Q360	G-3	Q545	F-6	R127	M-4	R148	M-4	R174	L-4	R212	N-5	R238	A-3	R260	B-4	R291	A-5	R320	K-5
CR365	H-4	CR418	I-4	Q160	M-4	Q270	A-4	Q365	G-4			R129	N-4	R150	K-4	R176	K-4	R214	M-5	R240	A-3	R265	A-4	R294	B-5	R324	I-5
CR366	H-4	CR420	J-2	Q165	D-5	Q285	B-4	Q370	G-4			R132	N-4	R152	N-4	R178	E-4	R215	M-5	R242	B-3	R267	B-3	R300	B-1	R326	H-5
CR382	G-3	CR424	J-2	Q167	K-4	Q290	B-5	Q380	G-1			R134	M-4	R154	N-3	R184	M-4	R220	M-5	R245	B-3	R270	B-6	R302	B-2	R328	I-5
CR384	H-2	CR540	G-5	Q176	K-3	Q305	A-2	Q500	G-5			R136	N-4	R156	N-3	R186	L-4	R226	P-6	R248	A-3	R272	J-5	R303	B-2	R330	J-3
CR386	H-2			Q178	D-5	Q315	K-5	Q510	G-5			R138	O-5	R158	K-3	R187	M-4	R228	O-5	R250	A-2	R273	J-5	R305	B-2	R334	H-5

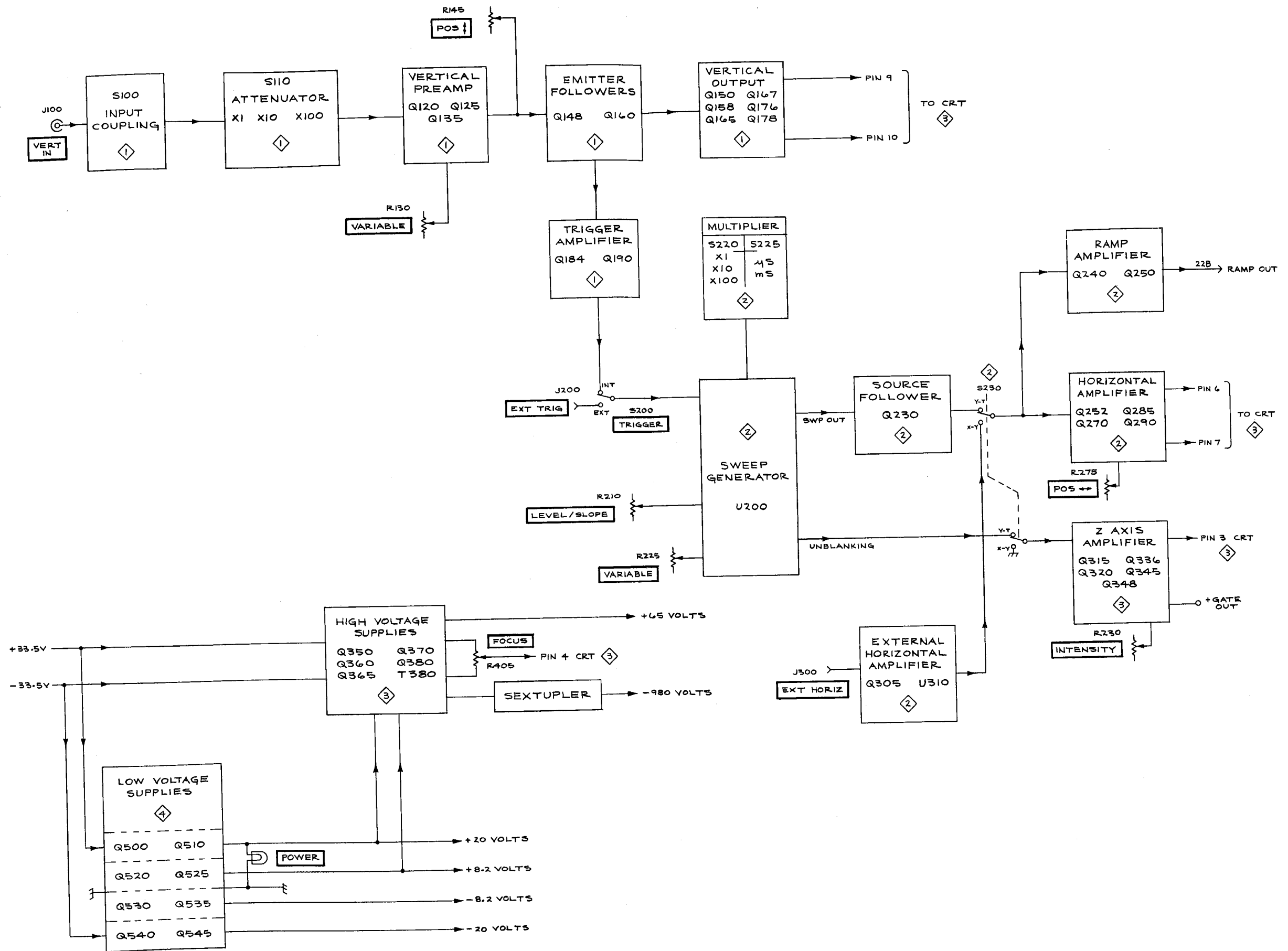

SC 501

(A)

BLOCK DIAGRAM DEH 0274

INPUT AND VERTICAL AMPLIFIER CIRCUIT DESCRIPTION

Input Attenuator. The input attenuators allow a choice of either X1, X10, or X100 attenuation of the input signal, which is ac- or dc-coupled by the selected position of S100. C112 and C104 allow the X10 and X100 attenuation networks to be frequency compensated. C117, C110, and C102 allow the attenuation networks to be normalized for a time constant of 47 microseconds.

Preamplifier. The preamplifier stage employs a dual field effect transistor, Q120, to provide a high input impedance. Q120B acts as a constant-current source for Q120A. Q125 and Q135 circuitry operates as a paraphase amplifier. Q148 and Q160 operate as emitter-followers to provide a low-impedance drive to the following stages. Quiescently, the two sides of the paraphase amplifier are balanced by the adjustment of R142 so that there is no current through the gain-setting resistor, R129, when the VARIABLE control is fully clockwise. The input stages are diode clamped by CR121 and CR125, protecting the input stages against negative-going over-drive signals. R130 (VARIABLE con-

trol) provides an adjustable attenuation factor other than the fixed calibrated values set by the input attenuators and the X1 position of R130.

Output Amplifier. A push-pull signal is developed at the emitters of Q148 and Q160, along with a dc positioning voltage from R145 (vertical POSITION control). The gain of the push-pull amplifier, consisting of Q150, Q158, Q167, and Q176, is controlled by Gain adjustment R172. The output stage, Q165 and Q178, with their associated components is a balanced grounded-base amplifier circuit which is protected from over-drive signals by clamping diodes, CR165 and CR178.

Trigger Takeoff. The trigger takeoff amplifier, Q184 and Q190, with their associated components, develops the internal signal to trigger the sweep generator. The gain of this stage is about seven.

CIRCUIT DESCRIPTION

ion- SC 501

N

or other than
tenuators and

veloped at the
dc positioning
rol). The gain
, Q158, Q167,
nt R172. The
air associated
mplifier circuit
by clamping

fier, Q184 and
develops the
r. The gain of

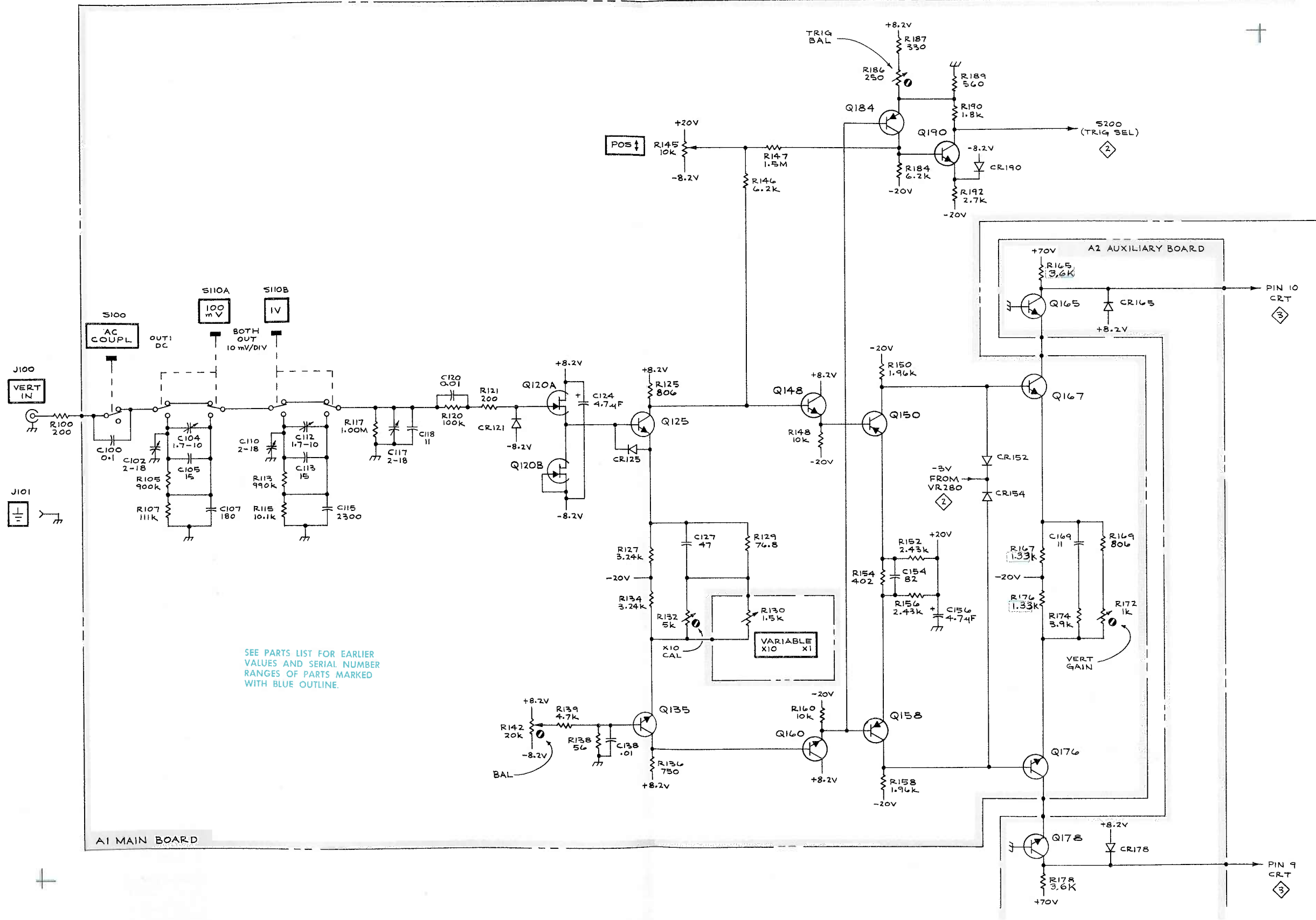

SWEEP AND HORIZONTAL AMP CIRCUIT DESCRIPTION

Trigger. Integrated circuit U200 is a combination Trigger/Sweep Generator. The Trigger portion (input pin 13) derives trigger pulses from a sample of the Vertical Amplifier signal, or from an external signal applied to the EXT TRIG pin jack. CR200 and CR201 limit the amplitude swing of the trigger signals. C204 is the differentiating capacitor for the trigger pulses. LEVEL/SLOPE control is provided by a voltage applied to pin 14 from R210. No trigger signals can start the sweep generator system until sweep hold-off period has been completed. The sweep hold-off periods (pin 3) are determined by the RC time constants of R215, C218, and C220. The timing period for the AUTO triggering mode is determined by the time constant of R205 and C205 if no voltage is applied to pin 10 through S205. For normal triggering, approximately -6 V is applied to pin 10 through S205.

Sweep Generator. The Sweep Generator portion of U200 produces two output signals; the sweep ramp voltage on pin 4 and crt unblanking gate on pin 16. The sweep is generated by a feedback operational amplifier integrating circuit. The slope of the ramp is controlled by fixed RC time constants selected by the Time/div pushbuttons. CR215 provides a low impedance discharge path for the sweep capacitors. Sweep length is controlled by a voltage applied to pin 6 from R212 (Sweep Adjust). Sweep VARIABLE control, R225, controls the charging current to the sweep (integrating) capacitors and when varied changes the slope of the ramp at pin 4.

Horizontal Amplifier. Sweep ramp voltages or signals from the EXT HORIZ pin jack are applied to the base of Q252. The circuit containing Q252 and Q270 is an emitter-coupled paraphase amplifier with a horizontal POSITION control voltage applied to the base of Q270 and R275. In the magnified mode, emitter degeneration is reduced, resulting in a X5 increase in gain. Clamping diodes, CR280 and CR282 limit the positive excursions of the signals at the bases of Q285 and Q290 to about -3 V as set by Zener diode, VR280. Push-pull signals are developed at the collectors of Q285 and Q290 to drive the horizontal deflection plates of the crt.

Ramp Out. The Ramp Out feedback amplifier circuit, Q240 and Q250, produces a zero to $+10$ V ramp or an amplified and inverted version of signals from the EXT HORIZ pin jack to the rear connector pins. The feedback arrangement allows the emitter of Q250 to be set to a zero volt dc level, and produces a low output impedance without causing Q240 to go into saturation.

External Horizontal Amplifier. The External Horizontal Amplifier circuit is an operational amplifier configuration, U310, fed by buffer amplifier Q305. The gain of U310 is fixed at about six by R310 and R305. R300 controls the external signal amplitude to the gate of Q305A.

CIRCUIT DESCRIPTION

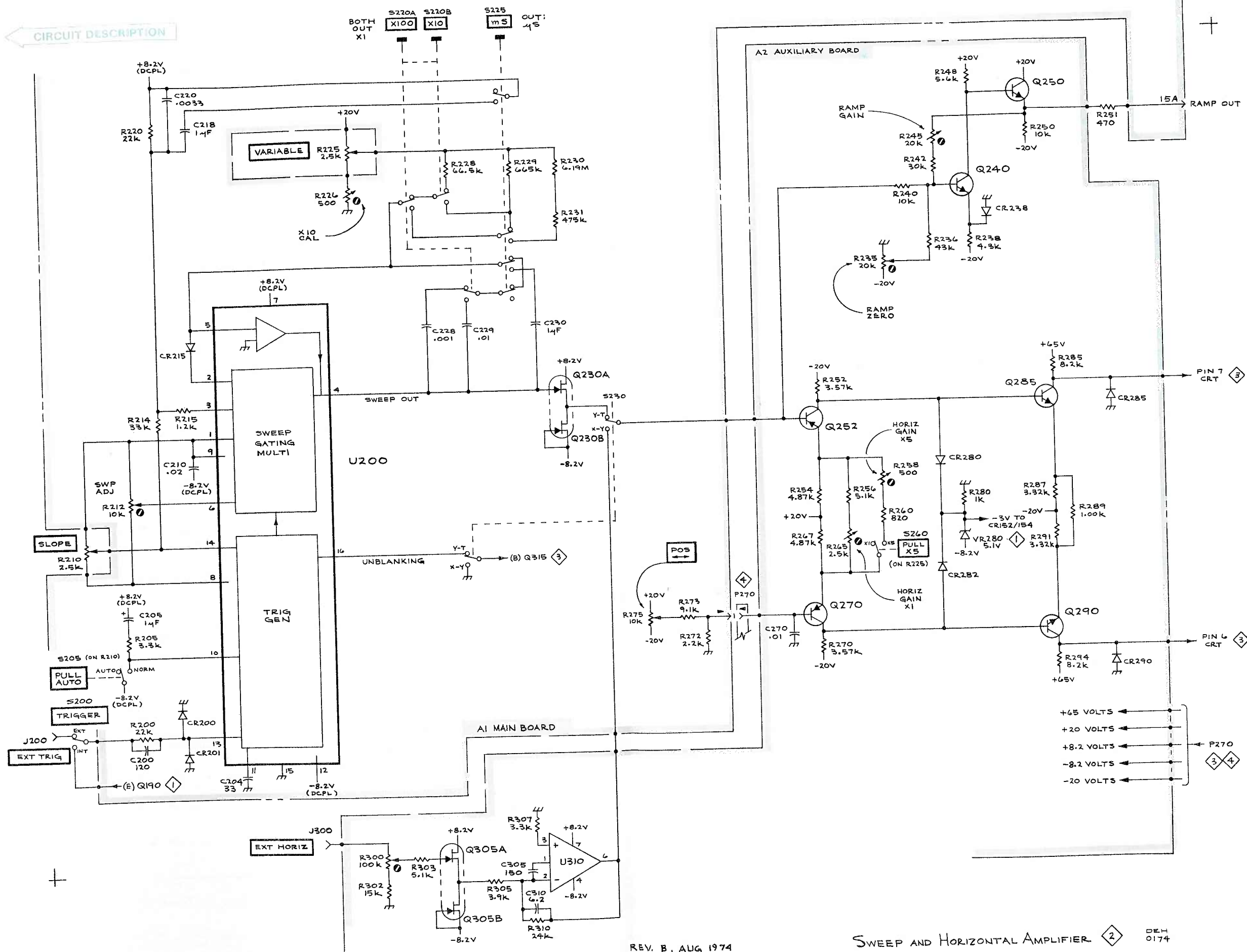

on-SC 501

es or signals
o the base of
Q270 is an
a horizontal
of Q270 and
generation is
mping diodes,
rsions of the
ut -3 V as set
developed at
the horizontal

mplifier circuit,
V ramp or an
from the EXT
. The feedback
be set to a zero
edance without

ernal Horizontal
r configuration,
gain of U310 is
00 controls the
15A.

Z-AXIS AND CRT CIRCUIT DESCRIPTION

Z-Axis Amplifier and + Gate Out. The Z-axis amplifier is a shunt-feedback operational amplifier with a voltage output. The amplifier consists of Q336, Q348, and Q345. The feedback path is from the collectors of Q345-Q348 through C339-R339 to the summing point at the base of Q336. Q345 and Q348 are connected as a complementary amplifier to provide a fast risetime signal while consuming minimum quiescent power. Q345 acts as a pull-up transistor and Q348 acts as the pull-down transistor for the amplifier. The output voltage from the amplifier provides the drive signal to control the crt intensity level through the control-grid supply.

Emitter-follower Q315, acts as a buffer amplifier for the Z-axis amplifier and + Gate Out circuits. The negative-going unblanking gate at the emitter of Q315 is coupled through CR334 to the Z-axis amplifier. The current through CR334 is set by R330, INTENSITY control. When R330 is set to +20 V, CR334 is cut off and the crt is blanked.

Cathode-Ray Tube Circuit. A repetitive, sinusoidal signal is produced by a regenerative feedback oscillator in the primary of T380 and induced into the secondary. Current drive for the primary winding is furnished by Q380, whose conduction is controlled by the voltage difference between its base and emitter. The secondary winding of T380 develops about 350 volts peak-to-peak. The sextupler rectifier circuit (six diodes in series) produces about -980 V dc at the crt directly-heated cathode (filament). A separate transformer tap and rectifier circuit, CR382, in the secondary of T380 produces about +70 V dc for the vertical, horizontal, and Z-axis amplifiers.

The 350 volts peak-to-peak output of T380 is also applied to CR415 and CR416 to provide the rectified negative potential for the crt control grid. CR420 limits the positive swing with respect to the + dc reference level set by Bias adjustment R425. CR418 limits the negative swing with respect to the output voltage level of the Z-axis amplifier. R410 connects the crt grid voltage to the crt filament (cathode) to ensure that the crt grid is more negative than -980 V (crt is cut off). A positive-going unblanking gate from the Z-axis amplifier decreases crt bias and intensifies the trace.

High voltage regulation is accomplished by sampling the -980 V across a voltage divider returned to +20 V (five 1 M Ω resistors in series with R362). A quiescent level of zero volts is established at the base of Q365, a Darlington amplifier. If the output level of the nominal -980 V goes more negative, the output level of Q365 goes more positive, reducing the conduction of Q370 and Q380. The result is a lower peak-to-peak amplitude induced in the secondary of T380. Conversely, if the -980 V goes more positive, Q380 will conduct harder and a larger peak-to-peak voltage appears across the secondary of T380. C367 limits the regulator bandwidth to prevent oscillations.

Q360 and Q350, and associated components, is a high voltage shut-down circuit. If the +70 V or -980 V supplies increase above the amplitude regulation limits, Q360 will turn on, reducing the voltage difference between the base and emitter of Q380 to near zero and removes the current drive to the primary of T380.

CIRCUIT DESCRIPTION

Q315 is also rectified limits the level set by positive swing the Z-axis to the crt d is more itive-going ses crt bias

impling the -20 V (five ent level of Darlington 980 V goes ore positive, e result is a ertiary of itive, Q380 ak voltage limits the

ts, is a high 0 V supplies , Q360 will een the base s the current

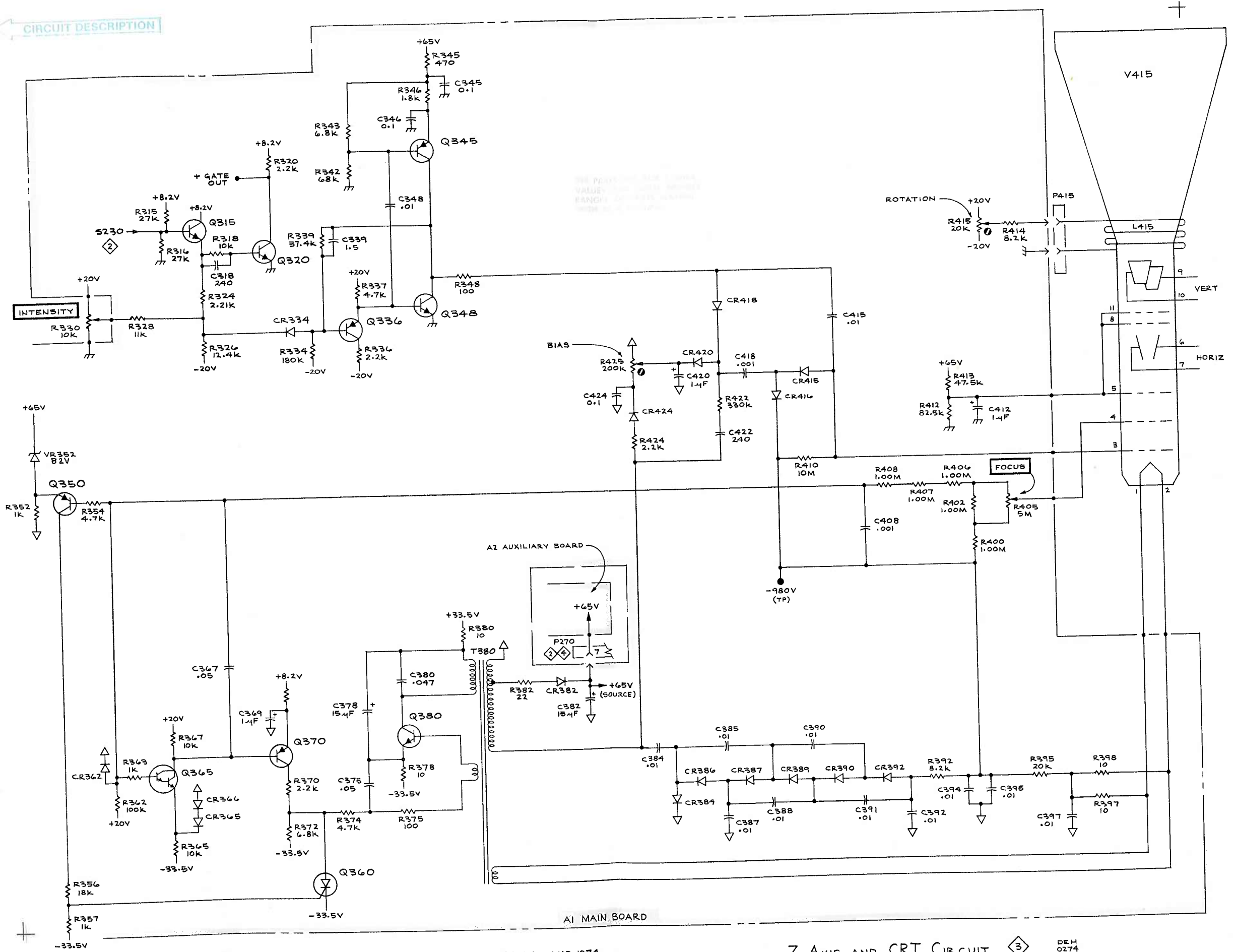

REV. B, AUG 1974

Z AXIS AND CRT CIRCUIT

DEM 0274

LOW VOLTAGE SUPPLY CIRCUIT DESCRIPTION

The +20 V supply provides power to operate the SC 501 and also establishes the reference supply for all other power supplies, including the crt system. An error-sensing circuit, Q500, compares a sample of the +20 V across a voltage divider (R507-R506-R504) with a reference voltage established by Zener diode, VR500. Any voltage difference (or change) between the base and emitter of Q500 is amplified by Q500 and applied to the base of Q510. This results in Q510 controlling (or regulating) the conduction of the PNP series-pass transistor (located in the mainframe) to correct for a change in the +20 V supply. R500 (+20 V Adjust) sets the quiescent level at the base of

Q500. R506 provides current limiting for Q500 in case Q510 fails. C505 prevents regulator oscillations. Bootstrapped emitter-followers, Q520 and Q525 regulate the +8.2 V supply in a manner similar to the operation of the +20 V regulator.

The -20 V and -8.2 V supplies are regulated in a manner similar to the +20 V and +8.2 V supplies, except that Q545 controls the conduction of the NPN series-pass transistor located in the mainframe. The reference voltage for the error-sensing circuit, Q540, is established by CR540.

CIRCUIT DESCRIPTION

C 501

in case
Boot-
ate the
of the

ad in a
except
ries-pass
voltage
CR540.

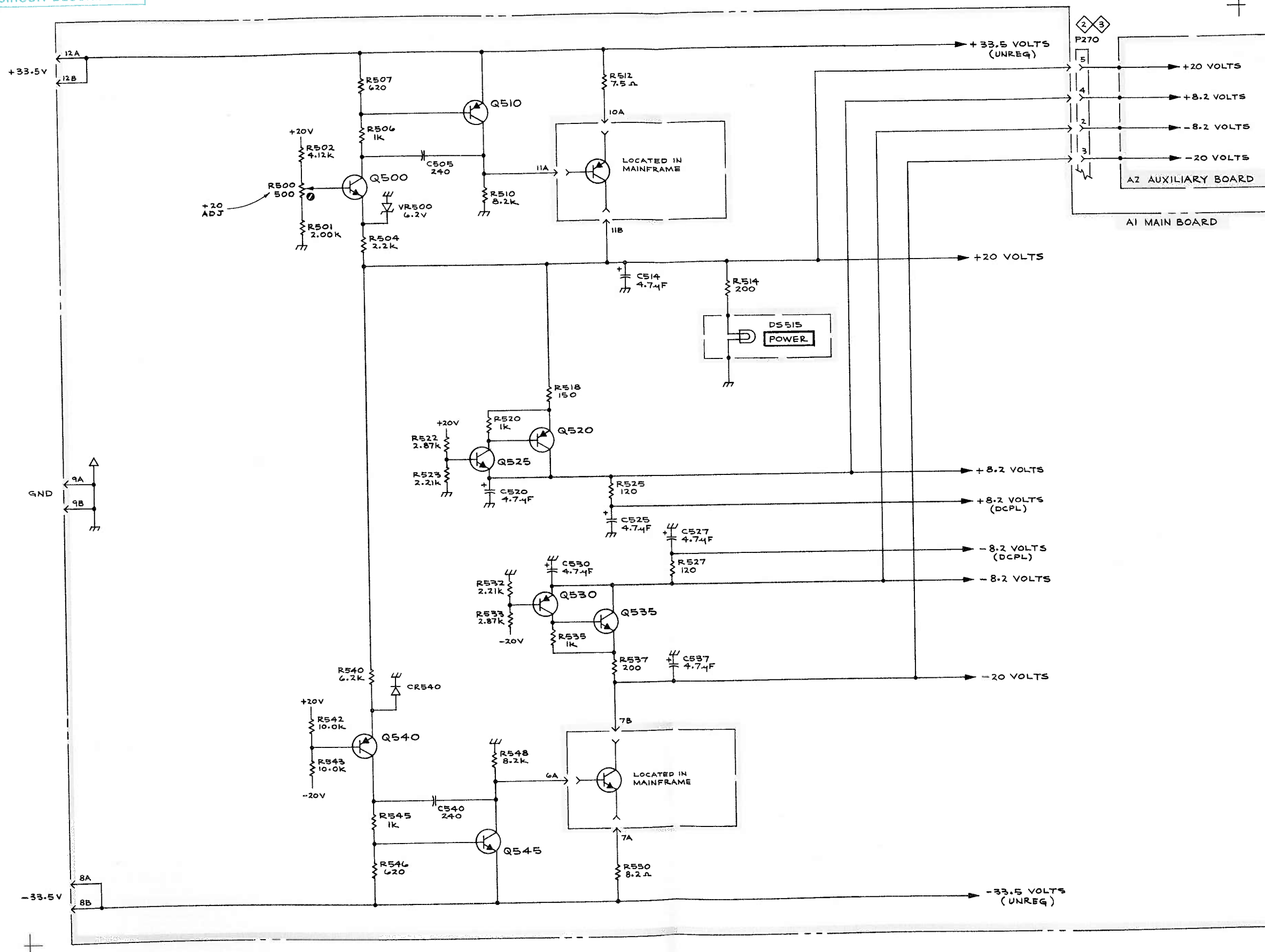

SC 501

(A)

LOW VOLTAGE SUPPLIES

4

DEH
0274

LOW VOLTAGE
SUPPLIES

4

MECHANICAL REPLACEABLE PARTS LIST

PARTS ORDERING INFORMATION

Replacement parts are available from or through your local Tektronix, Inc. Field Office or representative.

Changes to Tektronix instruments are sometimes made to accommodate improved components as they become available, and to give you the benefit of the latest circuit improvements developed in our engineering department. It is therefore important, when ordering parts, to include the following information in your order: Part number, instrument type or number, serial number, and modification number if applicable.

If a part you have ordered has been replaced with a new or improved part, your local Tektronix, Inc. Field Office or representative will contact you concerning any change in part number.

Change information, if any, is located at the rear of this manual.

SPECIAL NOTES AND SYMBOLS

X000 Part first added at this serial number

00X Part removed after this serial number

FIGURE AND INDEX NUMBERS

Items in this section are referenced by figure and index numbers to the illustrations.

INDENTATION SYSTEM

This mechanical parts list is indented to indicate item relationships. Following is an example of the indentation system used in the description column.

1	2	3	4	5	<i>Name & Description</i>
					<i>Assembly and/or Component</i>
					<i>Attaching parts for Assembly and/or Component</i>
					--- * ---
					<i>Detail Part of Assembly and/or Component</i>
					<i>Attaching parts for Detail Part</i>
					--- * ---
					<i>Parts of Detail Part</i>
					<i>Attaching parts for Parts of Detail Part</i>
					--- * ---

Attaching Parts always appear in the same indentation as the item it mounts, while the detail parts are indented to the right. Indented items are part of, and included with, the next higher indentation. The separation symbol --- * --- indicates the end of attaching parts.

Attaching parts must be purchased separately, unless otherwise specified.

ITEM NAME

In the Parts List, an Item Name is separated from the description by a colon (:). Because of space limitations, an Item Name may sometimes appear as incomplete. For further Item Name identification, the U.S. Federal Cataloging Handbook H6-1 can be utilized where possible.

ABBREVIATIONS

"	INCH	FLH	FLAT HEAD	PWR	POWER
#	NUMBER SIZE	FLTR	FILTER	RCPT	RECEPTACLE
ACTR	ACTUATOR	FR	FRAME or FRONT	RES	RESISTOR
ADPTR	ADAPTER	FSTNR	FASTENER	RDG	RIGID
ALIGN	ALIGNMENT	FT	FOOT	RLF	RELIEF
AL	ALUMINUM	FXD	FIXED	RTNR	RETAINER
ASSEM	ASSEMBLED	GSKT	GASKET	SCH	SOCKET HEAD
ASSY	ASSEMBLY	HDL	HANDLE	SCOPE	OSCILLOSCOPE
ATTEN	ATTENUATOR	HEX	HEXAGON	SCR	SCREW
AWG	AMERICAN WIRE GAGE	HEX HD	HEXAGONAL HEAD	SE	SINGLE END
BD	BOARD	HEX SOC	HEXAGONAL SOCKET	SECT	SECTION
BRKT	BRACKET	HLCPS	HELICAL COMPRESSION	SEMICOND	SEMICONDUCTOR
BRS	BRASS	HLEXT	HELICAL EXTENSION	SHLD	SHIELD
BRZ	BRONZE	HV	HIGH VOLTAGE	SHLDR	SHOULDERED
BSHG	BUSHING	IC	INTEGRATED CIRCUIT	SKT	SOCKET
CAB	CABINET	ID	INSIDE DIAMETER	SL	SLIDE
CAP	CAPACITOR	IDENT	IDENTIFICATION	SLFLKG	SELF-LOCKING
CER	CERAMIC	IMPLR	IMPELLER	SLVG	SLEEVING
CHAS	CHASSIS	IN	INCH	SPR	SPRING
CKT	CIRCUIT	INCAND	INCANDESCENT	SQ	SQUARE
COMP	COMPOSITION	INSUL	INSULATOR	SST	STAINLESS STEEL
CONN	CONNECTOR	INTL	INTERNAL	STL	STEEL
COV	COVER	LPHLDR	LAMPHOLDER	SW	SWITCH
CPLG	COUPLING	MACH	MACHINE	T	TUBE
CRT	CATHODE RAY TUBE	MECH	MECHANICAL	TERM	TERMINAL
DEG	DEGREE	MTG	MOUNTING	THD	THREAD
DWR	DRAWER	NIP	NIPPLE	THK	THICK
ELECTRN	ELECTRON	NON WIRE	NOT WIRE WOUND	TNSN	TENSION
ELEC	ELECTRICAL	OD	ORDER BY DESCRIPTION	TPG	TAPPING
ELECTLT	ELECTROLYTIC	OD	OUTSIDE DIAMETER	TRH	TRUSS HEAD
ELEM	ELEMENT	OVH	OVAL HEAD	V	VOLTAGE
EPL	ELECTRICAL PARTS LIST	PH BRZ	PHOSPHOR BRONZE	VAR	VARIABLE
EQPT	EQUIPMENT	PL	PLAIN or PLATE	W/	WITH
EXT	EXTERNAL	PLSTC	PLASTIC	WSHR	WASHER
FIL	FILLISTER HEAD	PN	PART NUMBER	XFMR	TRANSFORMER
FLEX	FLEXIBLE	PNH	PAN HEAD	XSTR	TRANSISTOR

CROSS INDEX MFR. CODE NUMBER TO MANUFACTURER

MFR.CODE	MANUFACTURER	ADDRESS	CITY, STATE, ZIP
00779	AMP, Inc.	P. O. Box 3608	Harrisburg, PA 17105
01295	Texas Instruments, Inc., Components Group	P. O. Box 5012	Dallas, TX 75222
10389	Chicago Switch, Inc.	2035 Wabansia Ave.	Chicago, IL 60647
22526	Berg Electronics, Inc.	Youk Expressway	New Cumberland, PA 17070
24931	Specialty Connector Co., Inc.	3560 Madison Ave.	Indianapolis, IN 46227
45722	USM Corp., Parker-Kalon Fastener Div.	1 PeeRay Drive	Clifton, NJ 07014
71159	Bristol Socket Screw, Div. of American Chain and Cable Co., Inc.	P. O. Box 2244	Waterbury, CT 06720
71590	Centralab Electronics, Div. of Globe-Union, Inc.	5757 N. Green Bay Ave.	Milwaukee, WI 53201
73743	Fischer Special Mfg. Co.	446 Morgan St.	Cincinnati, OH 45206
74445	Holo-Krome Co.	31 Brook St. West	Hartford, CT 06110
78189	Illinois Tool Works, Inc. Shakeproof Division	St. Charles Road	Elgin, IL 60126
79807	Wrought Washer Mfg. Co.	2100 S. O Bay St.	Milwaukee, WI 53207
80009	Tektronix, Inc.	P. O. Box 500	Beaverton, OR 97005
82647	Texas Instruments, Inc., Control Products Div.	34 Forest St.	Attleboro, MA 02703
83385	Central Screw Co.	2530 Crescent Dr.	Broadview, IL 60153
85471	Boyd, A. B., Co.	1233 Howard St.	San Francisco, CA 94103

FIGURE 1 EXPLODED

Fig. & Index No.	Tektronix Part No.	Serial/Model No. Eff Dscont	Qty						Name & Description	Mfr Code	Mfr Part Number	
				1	2	3	4	5				
1-1	337-1399-00		2							SHLD,ELECTRICAL:SIDE	80009	337-1399-00
-2	366-0494-00		3							KNOB:GRAY WITH SETSCREW	80009	366-0494-00
			-							. EACH KNOB INCLUDES:		
	213-0153-00		1							. SETSCREW:5-40 X 0.125 INCH,HEX SOC STL	74445	OBD
-3	366-1173-03		2							KNOB:CHARCOAL,W/SETSCREW	80009	366-1173-03
			-							. EACH KNOB INCLUDES:		
	213-0239-00		1							. SETSCREW:3-48 X 0.062 INCH,STL	71159	OBD
-4	366-1257-27		1							PUSHBUTTON:GRAY,AC COUP	80009	366-1257-27
-5	366-1257-54		1							PUSHBUTTON:GRAY,100MV	80009	366-1257-54
-6	366-1257-55		1							PUSHBUTTON:GRAY,1V	80009	366-1257-55
-7	366-1257-87		1							PUSHBUTTON:GRAY,X10	80009	366-1257-87
-8	366-1402-41		1							PUSHBUTTON:GRAY,X100	80009	366-1402-41
-9	366-1422-01		1							KNOB:LATCH	80009	366-1422-01
-10	214-1840-00		1							PIN,KNOB SECRG:	80009	214-1840-00
-11	366-1489-74		1							PUSHBUTTON:GRAY,MS	80009	366-1489-74
-12	426-0681-00		6							FR,PUSH BUTTON:GRAY PLASTIC	80009	426-0681-00
-13	384-1114-02		2							EXTENSION SHAFT:	80009	384-1114-02
-14	220-0633-00		1							NUT,PLAIN,KNURL:0.50-28 X 0.25 INCH,BRS	80009	220-0633-00
-15	355-0170-00		1							STUD,BDG POST:6-32 X 0.40 INCH LONG	80009	355-0170-00
-16	131-0955-00		1							CONNECTOR,RCPT,:BNC,FEMALE	24931	28JR200-1
-17			2							RES,VAR,NONWIRE: (SEE R210 & R225 EPL)		
										(ATTACHING PARTS)		
-18	210-0583-00		2							NUT,PLAIN,HEX.:0.25-32 X 0.312 INCH,BRS	73743	2X20319-402
-19	210-0940-00		2							WASHER,FLAT:0.25 ID X 0.375 INCH OD,STL	79807	OBD
-20	358-0378-00		2							BUSHING,SLEEVE:PRESS MOUNT	80009	358-0378-00
										- - - * - - -		
-21	260-1470-00		1							SWITCH,SLIDE:DPDT,0.5A,125VAC	10389	23-021-309
-22			1							RES,VAR: (SEE R130 EPL)		
										(ATTACHING PARTS)		
-23	210-0583-00		1							NUT,PLAIN,HEX.:0.25-32 X 0.312 INCH,BRS	73743	2X20319-402
-24	210-0940-00		1							WASHER,FLAT:0.25 ID X 0.375 INCH OD,STL	79807	OBD
										- - - * - - -		
-25	333-1890-00		1							PANEL,FRONT:SC 501	80009	333-1890-00
-26	214-1513-01		1							LCH,PLUG-IN RET:	80009	214-1513-01
										(ATTACHING PARTS)		
-27	213-0254-00		1							SCR,TPG,THD CTG:2-56X0.25"100 DEG,FLH STL	45722	OBD
										- - - * - - -		
-28	200-0935-00		1							BASE,LAMPHOLDER:0.29 OD X 0.19" L,BK PLSTC	80009	200-0935-00
-29	378-0602-00		1							LENS,LIGHT:GREEN	80009	378-0602-00
-30	352-0157-00		1							LAMPHOLDER:WHITE PLASTIC	80009	352-0157-00
-31	200-1555-01		1							BEZEL,CRT:	80009	200-1555-01
										(ATTACHING PARTS)		
-32	211-0101-00		2							SCREW,MACHINE:4-40 X 0.25" 100 DEG,FLH STL	83385	OBD
										- - - * - - -		
-33	386-2641-01		1							SUBPANEL,FRONT:PLASTIC	80009	386-2641-01
										(ATTACHING PARTS)		
-34	213-0229-00		3							SCR,TPG,THD FOR:6-20X0.375 100 DEG,FLH STL	83385	OBD
										- - - * - - -		
-35	337-2026-00		1							SHIELD,ELEC:REAR SUBPANEL	80009	337-2026-00
-36	384-1216-00		1							EXTENSION SHAFT:6.375 INCH LONG	80009	384-1216-00
-37	384-1217-00		1							EXTENSION SHAFT:8.45 INCH LONG	80009	384-1217-00
-38	384-1099-00		2							EXTENSION SHAFT:PUSH BUTTON,1.54 INCH LONG	80009	384-1099-00
-39	354-0423-00		1							RING,SPRT,CRT:RUBBER	80009	354-0423-00
-40	348-0279-00		1							CUSHION,CRT:	85471	OBD
-41	337-1458-03		1							SHLD,ELECTRON T:	80009	337-1458-03
										(ATTACHING PARTS)		
-42	211-0101-00		1							SCREW,MACHINE:4-40 X 0.25" 100 DEG,FLH STL	83385	OBD
										- - - * - - -		
-43	136-0611-00		1							SKT,ELCTR N TUBE:	80009	136-0611-00
			-							. SKT,ELECTRON TUBE ASSEMBLY INCLUDES:		
	136-0453-00		1							. SKT,ELCTR N TUBE:	80009	136-0453-00
	131-1109-00		10							. CONTACT,ELEC:	00779	42869-6
-44	343-0403-00		1							CLAMP,XSTR:	80009	343-0403-00
										(ATTACHING PARTS)		
-45	211-0114-00		1							SCREW,MACHINE:4-40 X 0.438 INCH L,FLH STL	83385	OBD
-46	342-0082-00		1							INSULATOR PL:	80009	342-0082-00
										- - - * - - -		

Mechanical Parts List—SC 501

FIGURE 1 EXPLODED (CONT)

Fig. & Index No.	Tektronix Part No.	Serial/Model No.		Qty	1 2 3 4 5	Name & Description	Mfr	
		Eff	Dscont				Code	Mfr Part Number
1-47	214-1061-00			1		SPRING,GROUND:FLAT	80009	214-1061-00
-48	426-1022-00			1		FR SECT,TOP: (ATTACHING PARTS)	80009	426-1022-00
-49	213-0146-00			1		SCR,TPG,THD FOR:6-20 X 0.313 INCH,PNH STL - - - * - - -	83385	OBD
-50	426-1047-00			1		FR SECT,BOTTOM: (ATTACHING PARTS)	80009	426-1047-00
	213-0146-00			1		SCR,TPG,THD FOR:6-20 X 0.313 INCH,PNH STL - - - * - - -	83385	OBD
-51	337-1839-00			1		SHIELD,ELEC:HI VOLT,RIGHT (ATTACHING PARTS)	80009	337-1839-00
-52	211-0008-00			1		SCREW,MACHINE:4-40 X 0.25 INCH,PNH STL	83385	OBD
-53	210-0994-00			1		WASHER,FLAT:0.125 ID X 0.25" OD,STL - - - * - - -	83385	OBD
-54	337-1842-00			1		SHIELD,ELEC:HI VOLT,LEFT (ATTACHING PARTS)	80009	337-1842-00
-55	211-0144-00			1		SCREW,MACHINE:4-40 X 0.1.312 INCH L,PNH STL	83385	OBD
-56	210-0994-00			1		WASHER,FLAT:0.125 ID X 0.25" OD,STL	83385	OBD
-57	361-0581-00			1		SPACER,SLEEVE:0.25 OD X 1.044 INCH LONG	80009	361-0581-00
-58	129-0419-00			1		POST,ELEMCH: - - - * - - -	80009	129-0419-00
-59	-----			1		CKT BOARD ASSY:(SEE A1 EPL)		
	-----			-		. CKT BOARD ASSY INCLUDES:		
-60	131-0608-00			8		. CONTACT,ELEC:0.365 INCH LONG	22526	47357
-61	136-0252-04			15		. SOCKET,PIN CONN:0.188 INCH LONG	22526	75060-001
-62	136-0260-02			1		. SOCKET,SEMICON:16 CONTACT,LOW CLEARANCE	01295	C931602
-63	214-0579-00			1		. TERM.,TEST PT:0.40 INCH LONG	80009	214-0579-00
-64	214-0973-00			1		. HEAT SINK,ELEC:0.28 X 0.18 OVAL X 0.187"H	80009	214-0973-00
-65	260-0723-00			1		. SWITCH,SLIDE:DPDT,0.5A,125VAC	80009	260-0723-00
-66	260-1332-00			1		. SWITCH,PUSH:1 BUTTON	71590	2KAB010010-XXX
-67	361-0542-00			2		. SPACER,SWITCH:PLASTIC	71590	J-64281
-68	337-1838-00			1		. SHIELD,ELEC:PUSHBUTTON	80009	337-1838-00
-69	260-1445-00			1		. SWITCH,PUSH:	80009	260-1445-00
	361-0542-00			2		. SPACER,SWITCH:PLASTIC	71590	J-64281
-70	260-1365-00			2		. SWITCH,PUSH:	80009	260-1365-00
-71	337-1837-00			1		. SHIELD,ELEC:PUSHBUTTON	80009	337-1837-00
-72	376-0051-01			4		. CPLG,SHAFT,FLEX:FOR 0.125 INCH - . COUPLING,SHAFT,FLEXIBLE INCLUDES:	80009	376-0051-01
	354-0251-00			2		. RING,COUPLING:	80009	354-0251-00
	376-0049-00			2		. CPLG,SHAFT,FLEX:PLASTIC	80009	376-0049-00
	213-0048-00			4		. SETSCREW:4-40 X 0.125 INCH HEX SOC STL	74445	OBD
-73	-----			3		. RES,VAR,NONWIR:(SEE R405 EPL)		
-74	-----			1		. RES,VAR,NONWIR:(SEE R145,R275 & R330 EPL) (ATTACHING PARTS)		
-75	210-0583-00			3		. NUT,PLAIN,HEX.:0.25-32 X 0.312 INCH,BRS	73743	2X20319-402
-76	210-0046-00			3		. WASHER,LOCK:INTL,0.26 ID X 0.40" OD,STL	78189	1214-05-00-0541C
-77	337-1840-00			1		. SHIELD,ELEC:POT MTG - - - * - - -	80009	337-1840-00
-78	-----			1		CKT BOARD ASSY:(SEE A2 EPL)		
	-----			-		. CKT BOARD ASSY INCLUDES:		
-79	136-0252-04			6		. SOCKET,PIN CONN:0.188 INCH LONG	22526	75060-001
-80	136-0514-00			1		. SOCKET,SEMICON:MICROCIRCUIT,8 CONTACT (ATTACHING PARTS)	82647	C930802
-81	210-0406-00			1		NUT,PLAIN,HEX.:4-40 X 0.188 INCH,BRS	73743	2X12161-402
-82	211-0144-00			1		SCREW,MACHINE:4-40 X 1.312 INCH L,PNH STL	83385	OBD
-83	213-0336-00			1		SCR,TPG,THD FOR:6-32 X 1.25 INCH,PNH STL	83385	OBD
-84	361-0671-00			2		SPACER,SLEEVE:0.189 OD X 1.06 INCH LONG - - - * - - -	80009	361-0671-00

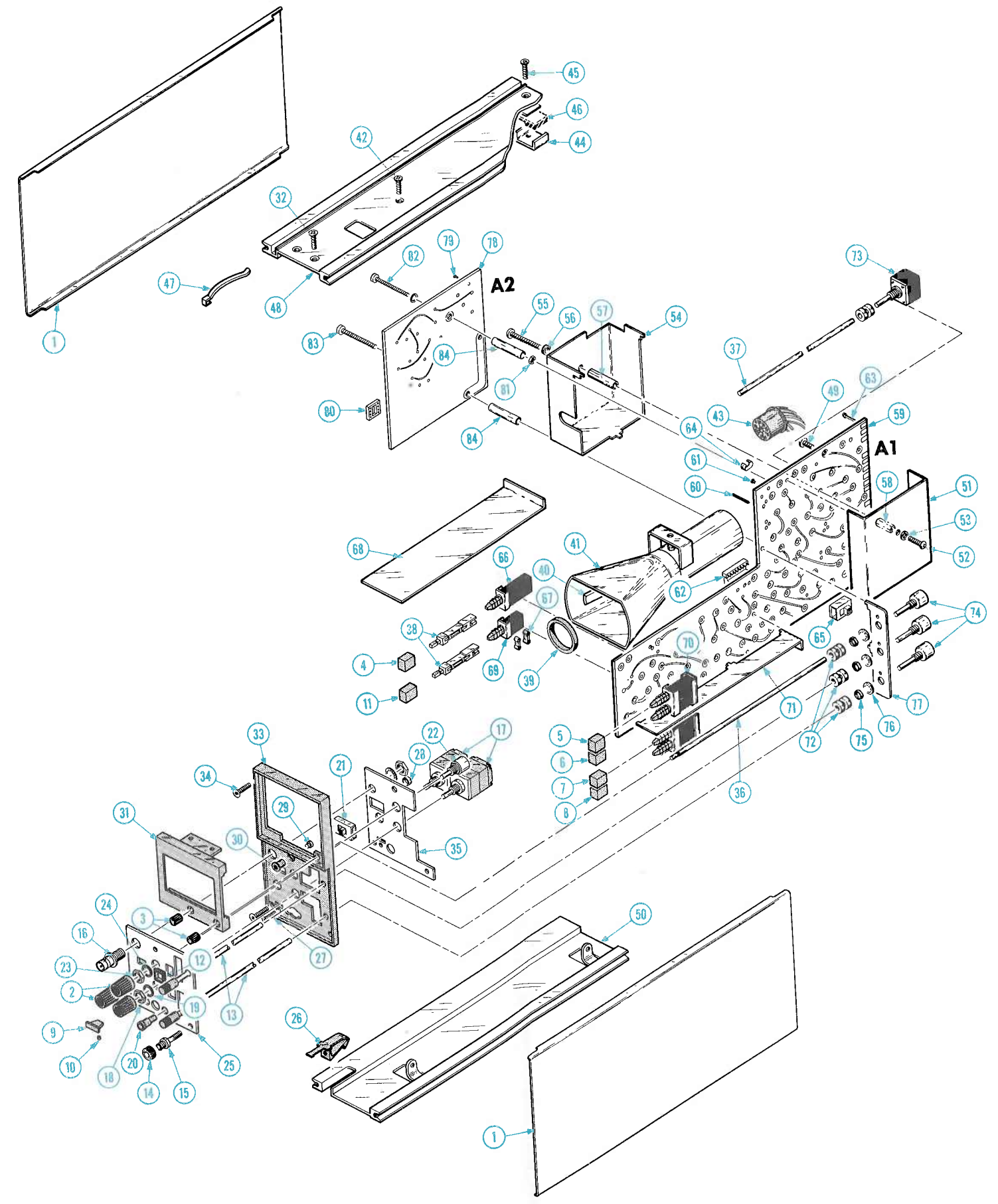

ACCESSORIES

Fig. & Index No.	Tektronix Part No.	Serial/Model No.		Qty	Name & Description					Mfr			
		Eff	Dscont		1	2	3	4	5	Code	Mfr Part Number		
2-	070-1700-00			1							MANUAL, TECH: INSTRUCTION	80009	070-1700-00

REPACKAGING

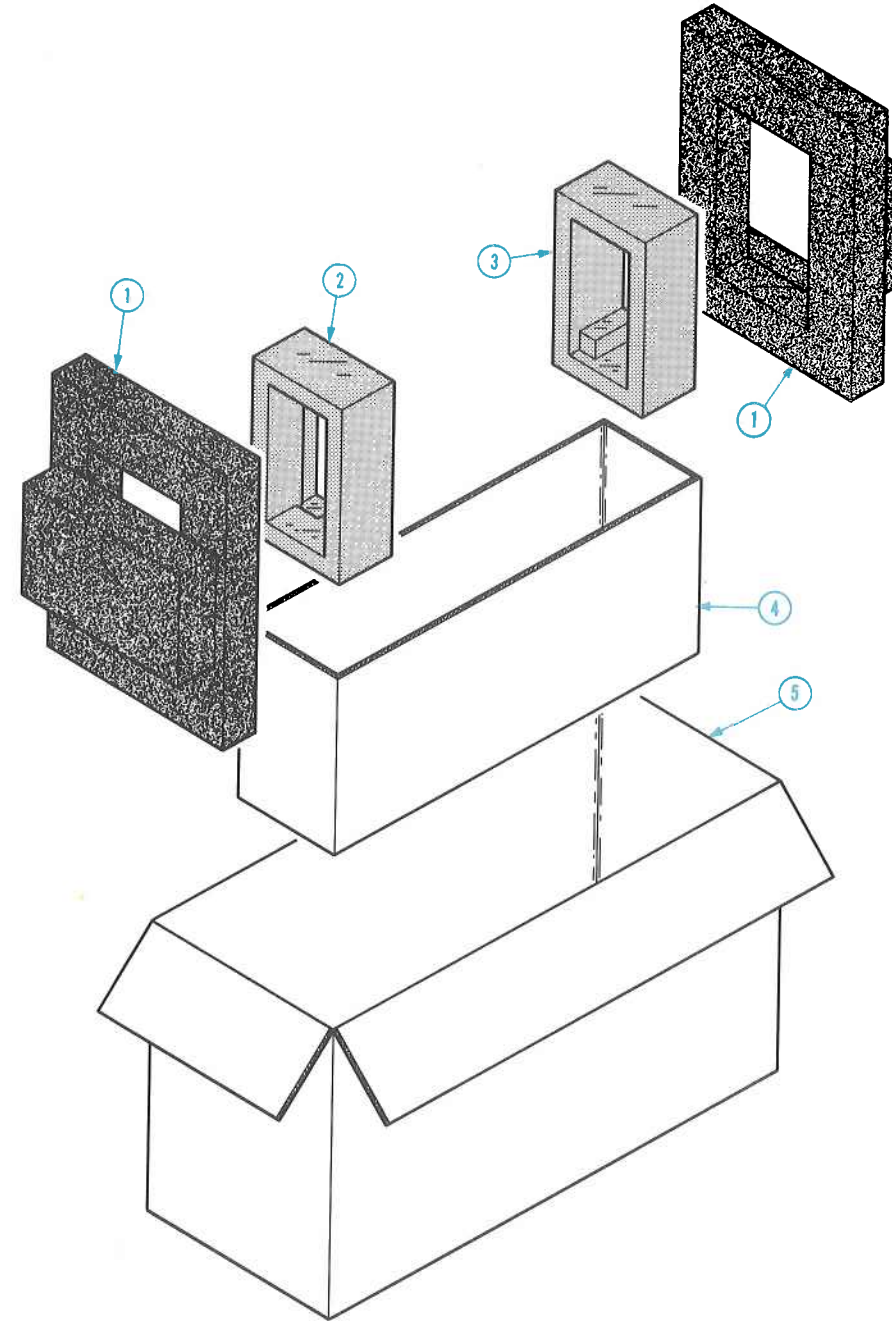

Fig. & Index No.	Tektronix Part No.	Serial/Model No.		Qty	Name & Description					Mfr			
		Eff	Dscont		1	2	3	4	5	Code	Mfr Part Number		
2-	065-0151-00			1							CARTON ASSEMBLY:	80009	065-0151-00
-				-							CARTON ASSEMBLY INCLUDES:		
-1	004-0282-00			2							FRAME: PLASTIC FOAM	80009	004-0282-00
-2	004-0243-00			1							PAD, CUSHIONING: FRONT	80009	004-0423-00
-3	004-0242-00			1							PAD, CUSHIONING: REAR	80009	004-0242-00
-4	004-1093-00			1							PAD, CUSHIONING: 13.375 X 3.25 X 5.625"	80009	004-1093-00
-5	004-0612-00			1							CARTON: 16.50 X 6.625 X 9.125 INCHES	80009	004-0612-00

MANUAL CHANGE INFORMATION

At Tektronix, we continually strive to keep up with latest electronic developments by adding circuit and component improvements to our instruments as soon as they are developed and tested.

Sometimes, due to printing and shipping requirements, we can't get these changes immediately into printed manuals. Hence, your manual may contain new change information on following pages.

A single change may affect several sections. Sections of the manual are often printed at different times, so some of the information on the change pages may already be in your manual. Since the change information sheets are carried in the manual until ALL changes are permanently entered, some duplication may occur. If no such change pages appear in this section, your manual is correct as printed.



MANUAL CHANGE INFORMATION

PRODUCT SC 501
070-1700-00

CHANGE REFERENCE C2/1-75
DATE 1-7-75

CHANGE:	DESCRIPTION
---------	-------------

CALIBRATION ADJUSTMENTS

Step 10

CHANGE: Adjust C112 to read: "Adjust C104"

CHANGE: Adjust C110 to read: "Adjust C102"

Step 11

CHANGE: Adjust C104 to read: "Adjust C112"

CHANGE: Adjust C102 to read: "Adjust C110"

INTERCHANGE: Circuit Board Step (circled) Notations 10 and 11.



TEKTRONIX®

committed to
technical excellence

MANUAL CHANGE INFORMATION

PRODUCT SC 501

CHANGE REFERENCE M23,539

EFF SN B050560-up

DATE 7-17-75

CHANGE:

DESCRIPTION

070-1700-00

ELECTRICAL PARTS LIST AND SCHEMATIC CHANGES

CHANGE TO:

A1	670-3304-02	CKT BOARD ASSY:MAIN
C154	281-0637-00	CAP.,FXD,CER DI:91 PF, 5%, 500V

(C154 is located on diagram 1 INPUT & VERT AMP)